



# B8000 Single Wall UDC

UDC SUMPS



Product Shown  
B8380-S30

## SIZES:

- 20" width at base

\*See page 2 for dimensions drawing and chart

## MATERIALS:

- Tank-grade fiberglass material allows our product to be exposed to fuel
- Epoxy coated galvanized steel

## OVERVIEW:

Compatible with all current motor fuels including renewable and biofuel, the B8000 Series Single Wall UDCs can be sized and tailored to any dispenser model. All metal work is galvanized and epoxy coated for superior corrosion resistance. Designed with a removable upper frame.

## SPECIFICATIONS:

- Compact design ideal for parallel/manifold piping systems and narrow islands
- Sized and tailored to most dispenser models
- Designed with a removable upper frame
- Electrical offset frame eliminates the need for conduit penetrations
- 30-year corrosion warranty
- UL2447 listed



# B8000 Single Wall UDC

UDC SUMPS

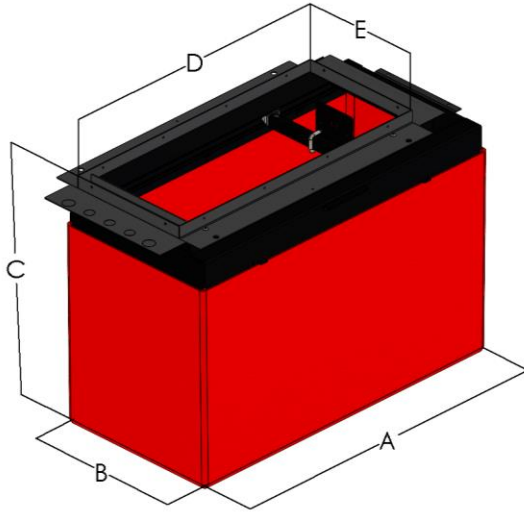

## Parts and Accessories

BK-8000	Boss-Mount Bracket for B8000 & B9000 series
BK-B2	Vapor Boss-Mount Bracket & U-Bolt Mount Bracket for B8000 & B9000 Series.
VST-UDC	VST, Vapor Stimulator Tube for UDC's, for Dri-Sump testing method, Clamp Included.

Dispenser Model	Part #	A	B	C	D	E
Gilbarco Encore 300, 500, 700	B8380-S30	41"	20"	30"	36"	15.25"
Wayne Ovation (3+0) (3+1) up to 3 inlets	B8250-S30	41"	20"	30"	40.5"	14.75"
Wayne Helix Wide Frame	B8256-S30	41"	20"	30"	40"	15"
Wayne Helix Narrow Frame	B8242-S30	29"	20"	30"	28.5"	14.75"
Wayne Ovation High-Speed Diesel/Ovation HL Series	B8254-S30	41"	20"	30"	40.5"	14.75"
Wayne Reliance Select	B8210-S30	29"	20"	30"	27.25"	15"
Gasboy Atlas X 9XXXG (Dispenser)	B8678-S30	29.5"	20"	30.5"	26.5"	14"
Bennett 3000 Big Fueler	B8430-S30	25.5"	20"	30"	23"	12.25"

Innovative Solutions for Secondary Containment

800-282-7286 | [www.sbravo.com](http://www.sbravo.com)