

RF-xx-01-U

INSTALLATION INSTRUCTIONS

BRAVO FIBERGLASS RETROFIT-S SERIES FOR SINGLEWALL FRP & STEEL SUMPS

FOR RETROFITTING ALL FLEXIBLE ENTRY BOOTS

FOR FIBERGLASS PIPE OR CONDUIT ONLY

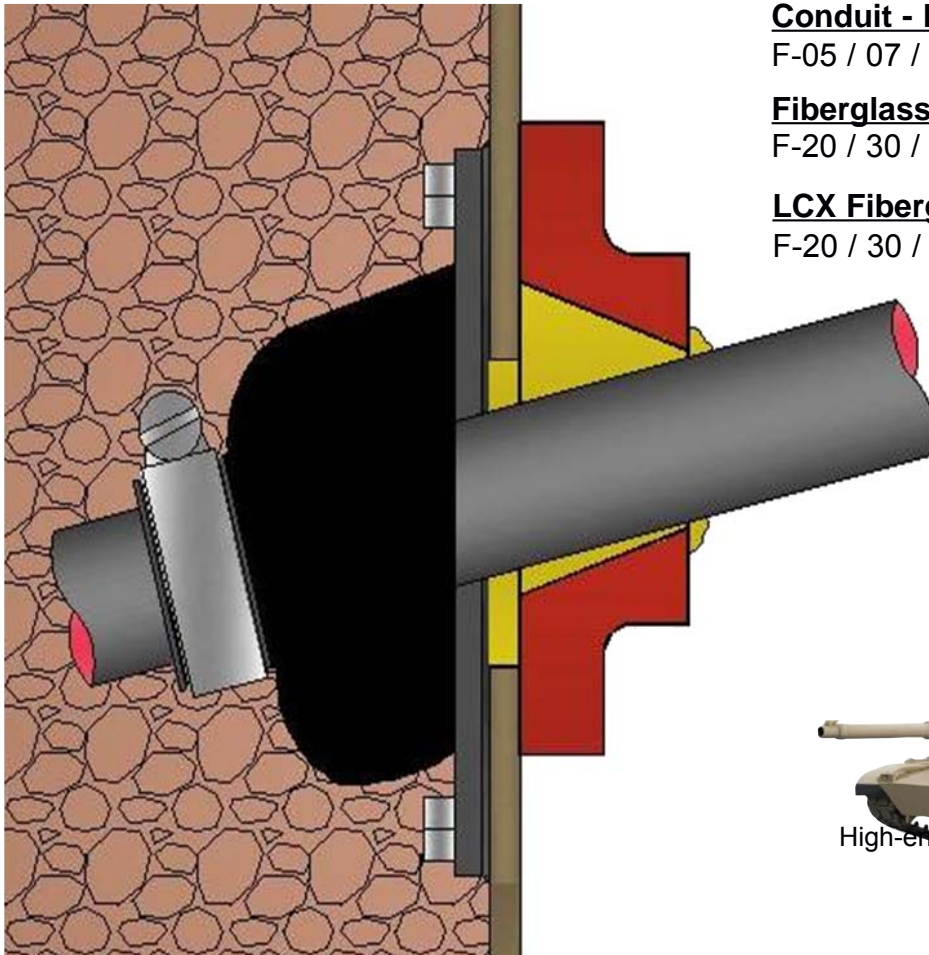

Conduit - Flat & Curved Wall

F-05 / 07 / 10-Retrofit-S & S-RND

Fiberglass Pipe - Flat & Curved Wall

F-20 / 30 / 40-Retrofit-S & S-RND

LCX Fiberglass Pipe - Flat & Curved Wall

F-20 / 30 / 40-Retrofit-S-LCX & S-LCX-RND



READ THIS MANUAL FRONT TO BACK

Note: Actual products may vary in appearance from illustrations in this manual

ii-F-Series-Retrofit-S-15A



WWW.SBRAVO.COM
800-AT-BRAVO



MANDATORY

The F-Series Singlewall Retrofit-S Fittings from S. Bravo Systems, Inc. MUST be installed by a **Bravo Retrofit-Certified Installer**. The **Retrofit Test** must be completed at www.sbravo.com/cert

COMPLETE KEEP TRACK of your job by taking advantage of the “Complete” checkboxes paired with each major step.

TABLE OF CONTENTS

- Fitting Warnings, Requirements & Warranty Terms..... p. 3
- Fitting Specifications and part numbers..... p. 4
- Fitting Components and Tools..... p. 5
- INSTALLATION SUMMARY**..... p. 6
- Step 1 Fitting rules, sump evaluation and cleanup..... p. 7
- Step 2 Removing the existing fitting on the interior..... p. 7
- Step 3 Wrapping pipe with rubber strip..... p. 8
- Step 4 Removing bolts and preparing the wall..... p. 8
- Step 5 Dry-fitting and outlining fitting position with marker..... p. 8
- PREPARING YOUR PIPE BY HAND SANDING**..... p. 9
- MIXING YOUR EPOXY - CRITICAL STEP**..... p. 10
- WINTER WARNING INSERT**
- Step 6 Gluing and Installing curved flange to wall..... p. 11
- Step 7 Gluing and Installing fitting body..... p. 12
- Step 8 Aligning and tightening clamp on fitting body..... p. 13
- Step 9 Lake testing (Water testing) your Installation..... p. 13

**If you have any problems with Bravo Systems components or accessories,
Contact Bravo Systems Immediately:**
1-800-28-BRAVO 1-323-888-4133 support@sbravo.com

LIMITED WARRANTY
Products sold by S. Bravo Systems, Inc. are warranted to be free from defects in material and workmanship for a period of one year from date of purchase. This warranty will be limited to the repair and replacement of Bravo parts only and will exclude all claims for labor or consequential damage. No other express warranties are given and no affirmation of S. Bravo Systems, Inc., or its agents and/or representatives, by words or action, will constitute a warranty. IT IS EXPRESSLY AGREED THAT THIS WARRANTY WILL BE IN LIEU OF ALL WARRANTIES OF FITNESS AND IN LIEU OF THE WARRANTY OF MERCHANTABILITY.

This warranty is void if there is any evidence of modification, abuse, negligence, or improper installation - including but not limited to installation or maintenance by a Non-Specialist Certified individual. If any fittings or components, other than S. Bravo Systems approved fittings or components, are used in conjunction with any S. Bravo Systems product, the warranty pertaining to these products is immediately void.



VENTILATE YOUR
AREA. WEAR MASK,
SAFETY GLASSES,
GLOVES AND OTHER
PROTECTION

NO

> ELECTRIC TOOLS
> IGNITION SOURCES



MANDATORY

Ensure that the workspace is operating below the LEL (lower explosive limit). Test regularly or monitor continuously.

NOTE:

BRAVO RECOMMENDS THAT AT A MINIMUM, all flexible entry fittings on a sump are retrofit with the F-Series Retrofit-S fitting. Having every entry fitting sealed with fuel-compatible epoxy will ensure the best test results.

**WARRANTY IS VOID
OR YOUR CERTIFIED STATUS
WILL BE REVOKED:**

IF ANY OF THE FOLLOWING OCCUR

- A) NOT** Installing an F-Series Retrofit-S fitting specifically with Bravo **EP100-RF** epoxy kits.
- B)** Installing a F-Series Retrofit-S fitting with epoxies that are not specified in this manual.
- C)** F-Series Retrofit-S Fittings are **NOT** installed by a **Bravo Certified Contractor**.
- D)** Installing a F-Series Retrofit-S fitting on Polyethylene sumps or flexible pipe.
- E)** Installing a F-Series Retrofit-S fitting without monitoring lower explosive limit.

FITTING MODELS FOR 0-20° DEGREE ADJUSTABILITY				ROUND AND FLAT WALLS		
Model Number	Wall type	Pipe type and size	Angle Adjustability	O.D.	Length	Epoxy Included
F-05-Retrofit-S	Flat/Round	1/2" Conduit / RobRoy	0 - 20° deg.	5"ø	2"	1
F-07-Retrofit-S	Flat/Round	3/4" Conduit / RobRoy	0 - 20° deg.	5"ø	2"	1
F-10-Retrofit-S	Flat/Round	1" Conduit / RobRoy	0 - 20° deg.	5"ø	2"	1
F-20-Retrofit-S	Flat/Round	2" Fiberglass	0 - 20° deg.	7"ø	2"	2
F-30-Retrofit-S	Flat/Round	3" Fiberglass	0 - 20° deg.	7"ø	2"	2
F-40-Retrofit-S	Flat/Round	4" Fiberglass	0 - 20° deg.	8"ø	2"	2
F-20-Retrofit-S-LCX	Flat/Round	2" Ameron LCX	0 - 20° deg.	7"ø	2"	2
F-30-Retrofit-S-LCX	Flat/Round	3" Ameron LCX	0 - 20° deg.	7"ø	2"	2
F-40-Retrofit-S-LCX	Flat/Round	4" Ameron LCX	0 - 20° deg.	8"ø	2"	2

FITTING MODELS FOR 20-45° DEGREE ADJUSTABILITY				FLAT WALLS ONLY		
Model Number	Wall type	Pipe type and size	Angle Adjustability	O.D.	Length	Epoxy Included
F-05-Retrofit-2045-S*	Flat	1/2" Conduit / RobRoy	20 - 45° deg.	7"ø	2"	3
F-07-Retrofit-2045-S*	Flat	3/4" Conduit / RobRoy	20 - 45° deg.	7"ø	2"	3
F-10-Retrofit-2045-S*	Flat	1" Conduit / RobRoy	20 - 45° deg.	7"ø	2"	3
F-20-Retrofit-2045-S*	Flat	2" Fiberglass	20 - 45° deg.	7"ø	2"	4
F-30-Retrofit-2045-S*	Flat	3" Fiberglass	20 - 45° deg.	8"ø	2"	5
F-40-Retrofit-2045-S*	Flat	4" Fiberglass	20 - 45° deg.	9"ø	2-1/2"	5
F-20-Retrofit-2045-S-LCX*	Flat	2" Fiberglass	20 - 45° deg.	8"ø	2"	4
F-30-Retrofit-2045-S-LCX*	Flat	3" Fiberglass	20 - 45° deg.	9"ø	2"	5
F-40-Retrofit-2045-S-LCX*	Flat	4" Fiberglass	20 - 45° deg.	11"ø	2-1/2"	5

FITTING MODELS FOR 20-45° DEGREE ADJUSTABILITY				ROUND WALLS ONLY		
Model Number	Wall type	Pipe type and size	Angle Adjustability	O.D.	Length	Epoxy Included
F-05-Retrofit-2045-S-RND*	Round	1/2" Conduit / RobRoy	20 - 45° deg.	7"ø	2"	3
F-07-Retrofit-2045-S-RND*	Round	3/4" Conduit / RobRoy	20 - 45° deg.	7"ø	2"	3
F-10-Retrofit-2045-S-RND*	Round	1" Conduit / RobRoy	20 - 45° deg.	7"ø	2"	3
F-20-Retrofit-2045-S-RND*	Round	2" Fiberglass	20 - 45° deg.	7"ø	2"	4
F-30-Retrofit-2045-S-RND*	Round	3" Fiberglass	20 - 45° deg.	8"ø	2"	5
F-40-Retrofit-2045-S-RND*	Round	4" Fiberglass	20 - 45° deg.	9"ø	2-1/2"	5
F-20-Retrofit-2045-S-LCX-RND*	Round	2" Fiberglass	20 - 45° deg.	8"ø	2"	4
F-30-Retrofit-2045-S-LCX-RND*	Round	3" Fiberglass	20 - 45° deg.	9"ø	2"	5
F-40-Retrofit-2045-S-LCX-RND*	Round	4" Fiberglass	20 - 45° deg.	11"ø	2-1/2"	5

* All 20-45° Degree models include an Offset Plate kit

OFFSET PLATES FOR GREATER WALL CONTACT	
Model Number	Description
F-2x7-OFFSET-S	2" I.D. x 7" O.D. split FRP offset for Flat Walls
F-2x7-OFFSET-S-RND	2" I.D. x 7" O.D. split FRP offset for Curved Walls
F-5x10-OFFSET-S	5" I.D. x 10" O.D. split FRP offset for Flat Walls
F-5x10-OFFSET-S-RND	5" I.D. x 10" O.D. split FRP offset for Curved Walls

EP100-RF	7oz epoxy kit
----------	---------------



High-end materials match UST spec UL1316 to ensure longevity and fuel compatibility

F-Series Retrofit-S COMPONENTS

Included Parts (Per fitting)

- A) 1x Fiberglass Retrofit-S Body (two halves) with SS Pipe Clamp
- B) 1x Loose Fiberglass Flange for curved walls (two halves) with 2 Zip-Ties
- C) Bravo **EP100-RF** epoxy kit: (quantity chart on page 4)
 - 1x Bravo Epoxy Can 6oz
 - 1x Bravo Epoxy Catalyst bottle 1oz
 - 2x Pair of Industrial Nitrile gloves (Large)
 - 1x Stir stick
 - 1x 1" chip brush
- D) 1x 60 grit emery cloth strip
- E) 1x 80 grit sheet of sandpaper
- F) For "2045" Extreme-Angle fitting for curved sumps: 1x Offset plate kit

REQUIRED TOOLS

(NOT PROVIDED)

Air Sander and Air Drill
Steel Stator Mixer
Eye protection
Respiratory protection

Approved Bonding Epoxy:
Bravo "EP100-RF"

MANDATORY

A Confined-space
Certification is required
when installing this fitting
inside Tank Sumps

⚠ CRITICAL

**USE ONLY BRAVO SYSTEMS EPOXY WHEN INSTALLING THIS
FITTING TO FIBERGLASS PIPE OR CONDUIT**

**DO NOT SUBSTITUTE EPOXIES, MIX THEM OR ADD
LIQUIDS SUCH AS WATER OR ANOTHER RESIN. DO NOT USE
ANOTHER CATALYST OTHER THAN WHAT IS PROVIDED.**

Summary of Installation

These steps are not a substitute for the detailed installation steps contained in the following pages.

DO NOT ATTEMPT TO INSTALL THIS PRODUCT BASED ONLY ON THE SUMMARIZED STEPS LISTED ON THIS PAGE

- 1) Read the entire manual front to back, read carefully. Do not just view images.
- 2) Evaluate the sump, ensure sump material is FRP or steel, and the piping is FRP or conduit.
- 3) Remove any necessary components that will obstruct your access to the sump wall.
Excavate adequate area on outside of all fittings you will install.
- 4) Clean each sump. Remove all contaminants, water and debris. Ensure each sump will be completely dry during all installation steps.
- 5) Secure conduit endpoints so they do not move or act as a lever.
- 6) Remove the interior boot and all of it's components or sealants from the wall and pipe.
- 7) Push existing bolts back into the backfill. Do not damage the sump wall doing this.
- 8) Properly protect the pipe or conduit against damage.
- 9) Abrade the interior of sump wall around hole until bare fiberglass is shown.
- 10) Clean, dry and rough up pipe or conduit surface in preparation for bonding.
- 11) Dust off all abraded surfaces with compressed air.
- 12) Dry-fit your fittings for clean fit against the wall and piping. Mark alignment stripe across the fitting halves and the sump wall with a permanent marker.
- 13) Bond split fitting to the interior of sump by manually pressing fitting halves firmly against the sump wall using hand strength.
- 14) Bead excess epoxy around primary seam at the wall and at the pipe.
- 15) Use acetone to clean the face of each fitting to look like a new install. Clamp halves together tight and re-clean any epoxy that oozes.
- 16) Allow epoxy to fully cure before testing fitting installation. Do not disturb while curing!
- 17) Mandatory Pressure/soap test to verify the fitting installation is good.

VENTILATE YOUR AREA
WEAR SAFETY PROTECTION

NO

> ELECTRIC TOOLS
> IGNITION SOURCES



MANDATORY

Ensure that the workspace is operating below the LEL (lower explosive limit) before starting work. Test regularly or monitor continuously

MANDATORY

A Confined-space Certification is required when installing this fitting inside Tank Sumps

STEP 1

BEFORE BEGINNING WORK ON YOUR JOBSITE. YOU MUST EVALUATE THE EXISTING SUMPS, PIPE, CONDUIT AND FLEXIBLE ENTRY BOOTS YOU WILL BE RETROFITTING. FOLLOW THESE STEPS:

- A) Ensure the sump material is fiberglass or steel only.
- B) Ensure the piping is fiberglass, galvanized steel or PVC coated steel only.
- C) If the PVC coated conduit is Ocal-Blue brand, you must strip the PVC away from the fitting area and rough up the steel conduit beneath.
- D) Ensure that the conduit has not rusted through. This fitting should not be installed to a corroded or partially corroded conduit line. In this case you must replace the conduit.

WHEN READY, BEGIN WORK ON YOUR JOBSITE BY ENTERING ALL THE SUMPS YOU WILL BE INSTALLING THE F-SERIES RETROFIT-S FITTING IN AND:

- E) Remove or move any components that will obstruct your access to the sump wall.
- F) Remove any fuel, oils, contaminants, water or debris. Dispose of HAZMAT per local codes.
- G) Secure all conduit lines by bracketing them to at least one rigidly connected conduit or the riser. Do not allow conduit endpoints to move or act as a lever.

STEP 2

COMPLETE

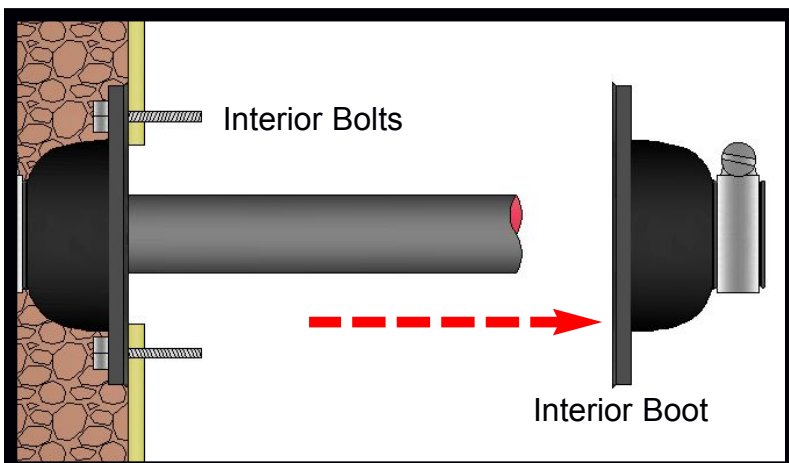

Before starting work, ensure all fuels and flammables have been removed. Test/monitor your LEL's and ventilate.

Remove interior boot from the wall to expose the fitting interior and bolts. **DO NOT USE TOOLS THAT CAN DAMAGE THE PIPE.**

Use a protractor or other measurement tool to measure piping angles.

STEP 3

COMPLETE

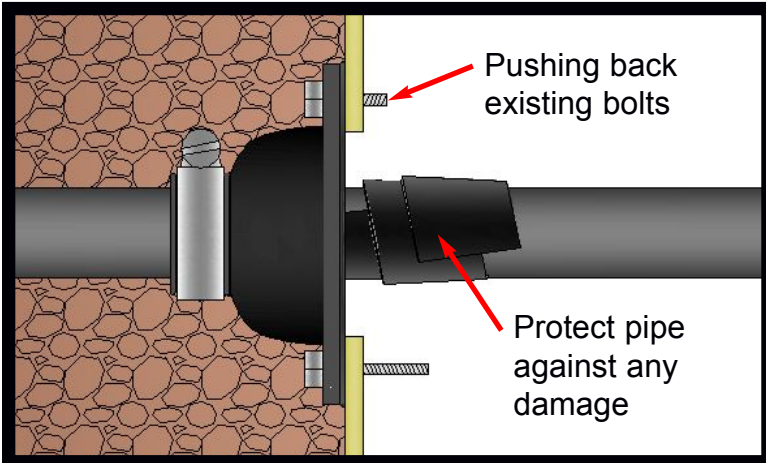

Before starting work, ensure all fuels and flammables have been removed. Test/monitor your LEL's and ventilate.

Push the bolts back into the backfill. Most bolts move backwards easily. DO NOT DAMAGE THE SUMP WALL!

Properly protect your piping from power or sharp tools. DO NOT DAMAGE PIPE!

STEP 4

COMPLETE

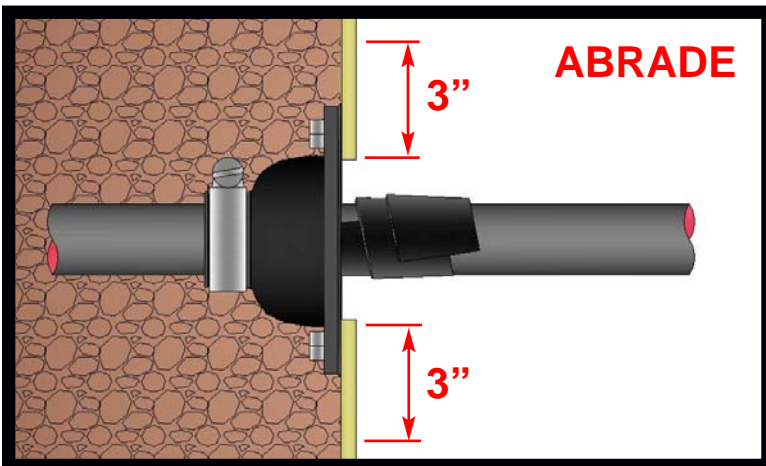

Proceed to grind your walls clean of any paint, gel-coat, epoxies, adhesives or sealants until open fiberglass is clearly visible 3 INCHES AWAY FROM THE HOLE, all the way around.

WARNING! For steel sumps, you must be extremely careful about sparking when abrading. If the steel is epoxy coated, it must be removed. You can only bond the Retrofit-S fitting to bare, clean and abraded steel.

STEP 5

MANDATORY

COMPLETE

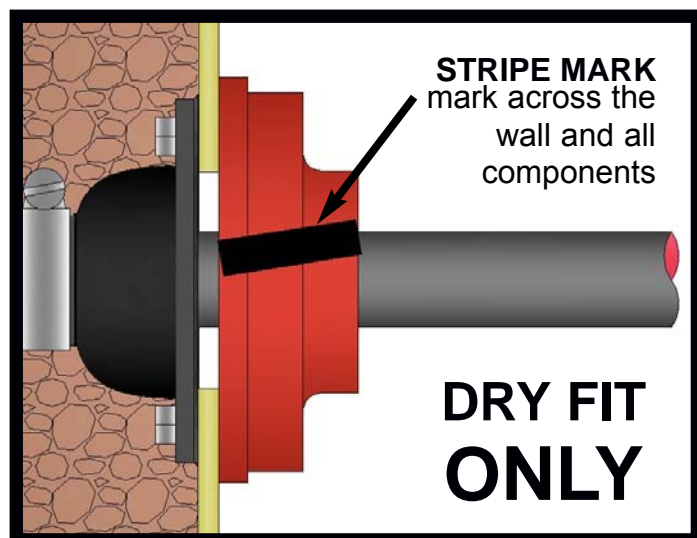

SECURE ALL CONDUIT LINES BY BRACKETING THEM TO AT LEAST ONE RIGIDLY CONNECTED CONDUIT OR THE RISER. DO NOT ALLOW CONDUIT ENDPOINTS TO MOVE OR ACT AS A LEVER.

FLAT WALLS: Dry fit the body on your pipe and use a marker to outline the fittings position on the wall. The curved flange will not be used.

CURVED WALLS: Dry fit the body and the curved flange and use a marker to mark a large stripe across the sump wall, body and flange. Also outline the fittings position when dry fit.

ROUGHING-UP YOUR FRP PIPE WITH SAND STRIP



Your pipe must be hand roughed in preparation for Gluing

DO NOT USE ANY POWER TOOLS ON PIPE, EVER!

MIXING YOUR EPOXY

Your epoxy should be stored in a cool place until ready to be mixed. You should warm your epoxy and fiberglass fitting components if the ambient temperature is below 70°F.

**DO NOT MIX MORE THAN ONE CAN AT A TIME
DO NOT ATTEMPT TO MIX HALF A CAN
ONLY USE 1 BOTTLE OF CATALYST PER EPOXY CAN**

⚠ CRITICAL

USE ONLY BRAVO SYSTEMS EPOXY WHEN INSTALLING THIS FITTING TO FIBERGLASS PIPE OR CONDUIT

DO NOT SUBSTITUTE EPOXIES, MIX THEM OR ADD LIQUIDS SUCH AS WATER OR ANOTHER RESIN. DO NOT USE ANOTHER CATALYST OTHER THAN WHAT IS PROVIDED.

⚠ CRITICAL

EPOXY HAS AN ACTIVE COLORANT

ADD CATALYST TO EPOXY AND MIX THOROUGHLY UNTIL THE COLOR IS EVEN AND CONSISTENT WITH NO SWIRLS



EPOXY WINTER WARNING

FOR COLD WEATHER AT 50°F DEGREES OR LESS: OBSERVE AND FOLLOW THE WARNINGS BELOW

NOTE: THESE GUIDELINES ARE NOT FOR BRAVO'S LAMINATING RESIN

Bravo bonding epoxies and epoxy-based slurries require a specific temperature range to properly cure and result in the best bond strength. In lower temperatures, you must apply and maintain adequate heat per the supplied cure chart to both the epoxy materials, containment sumps and entry fittings (if Bravo fiberglass type) to allow a full cure time. Failing to keep all bonding surfaces clean of contamination or failure to allow a full cure time may cause the epoxy bond to fail. In the case with Bravo Epoxy, there is no danger in applying it thick or heavy. The generous amount of epoxy required to gap-fill voids inherent in Retrofit entry fittings, or in the case of Epoxy Slurry pour joints on containment sumps such as the B-7000 or B-407 series there is very little loss of bond strength when our epoxy is applied or poured as a thick mass or volume.



Follow safety regulations and procedures including using intrinsically safe non-sparking devices and equipment. Clean work areas of fuel and flammable materials, wear required PPE (Personal Protective Equipment) ventilate fumes and monitor LEL levels in confined spaces.

Ambient Temp. (F°)	Work Time	Cure Time
LESS THAN 60°	WARM EPOXY TO 70°	
60°F (16°C)	45 min	6 hours
70°F (21°C)	30 min	3 hours
80°F (27°C)	25 min	2.5 hours
90°F (32°C)	15 min	2 hours
MORE THAN 90°	CHILL EPOXY TO 70°	

Follow these guidelines during cold weather to successfully bond your Bravo products:

A) Pre-heating components in cold weather is critical, Heat soak the following components accordingly and devise a safe way to maintain an ambient temperature per the cure chart above:

- > Pre-heat the sump wall to no more than ~150°F
- > Pre-heat each Bravo fiberglass fitting thoroughly to ~150°F
- > Pre-heat the epoxy or EP-slurry to ~80°F. **DO NOT HEAT THE CATALYST!!**

B) Do not adjust, move, shift or otherwise disturb the sump, fittings or piping while it cures.

C) You must ensure a full temperature/time cure before testing your Bravo products. Refer to the cure chart on your epoxy container.

D) You can test the hardness of the cured epoxy by pressing a blunt instrument into the surface, such as a ball point pen or screwdriver. It should not be soft or indent if it is fully cured.

The methods used to initially heat containment sumps, fiberglass entry fittings, piping, epoxy materials and also maintain such heat are up to the installing contractor. Common tools and techniques are permitted by Bravo as long as they do not create a safety concern or violate any worker safety or environmental regulations. If heat is applied to a sump interior, it must be loosely capped so the heat can be properly maintained. If heat packs or blankets must be used, they should be insulated against contact with the ambient air whether there is a wind or not.

STEP 6

COMPLETE

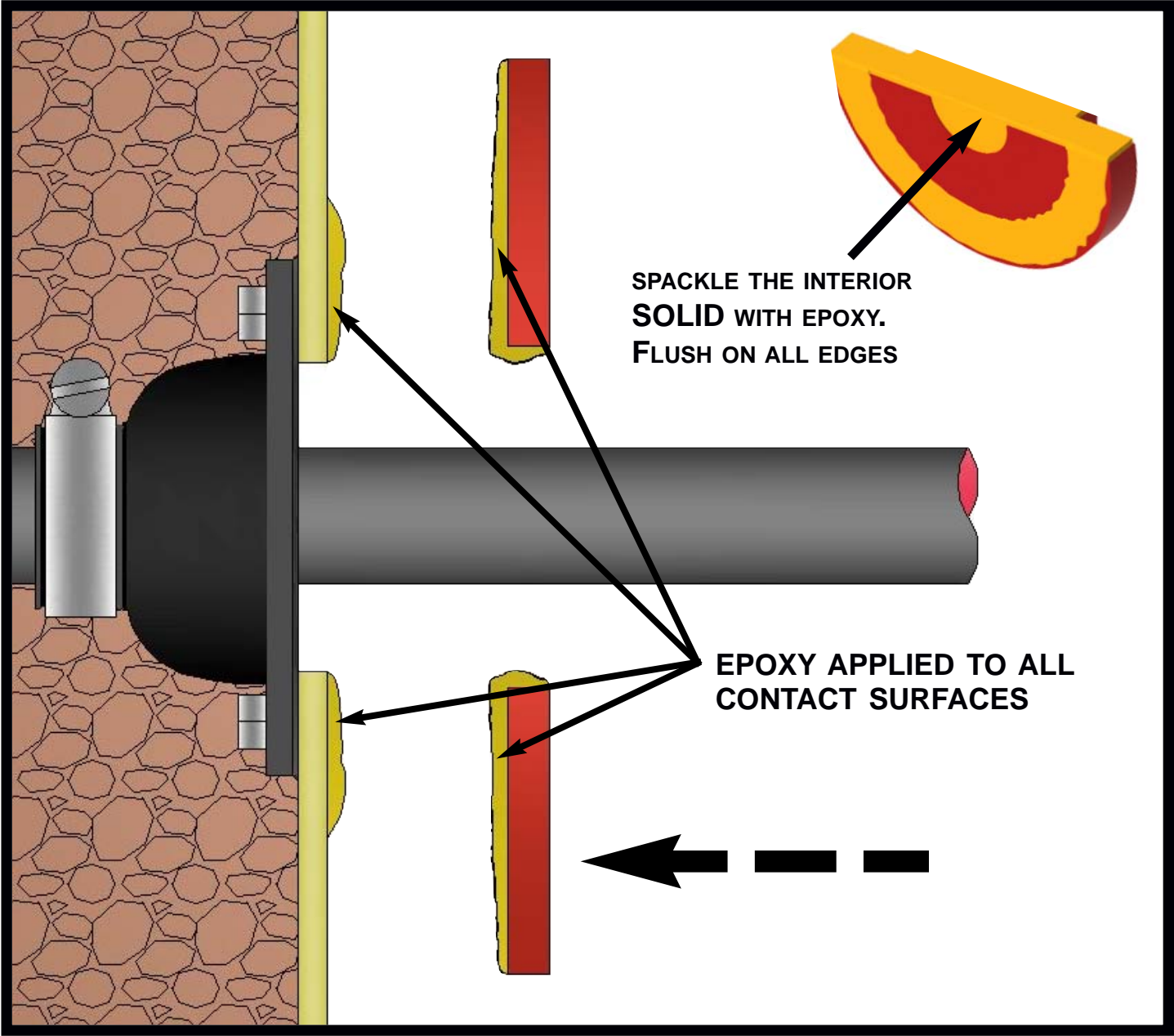

FOR CURVED WALLS:

Apply Bravo epoxy to all Contact Surfaces; between both halves of the curved flange or wedge where they contact each other, the pipe, the wall, and the face of the flange that will contact the wall. Stick this assembly to the wall by firmly applying manual pressure. Make sure to align the marked stripe. Use provided zip-tie to lock these halves together tightly. In weather below 90°F this should remain in place without any assistance while you prepare the body for gluing.

STEP 7

COMPLETE

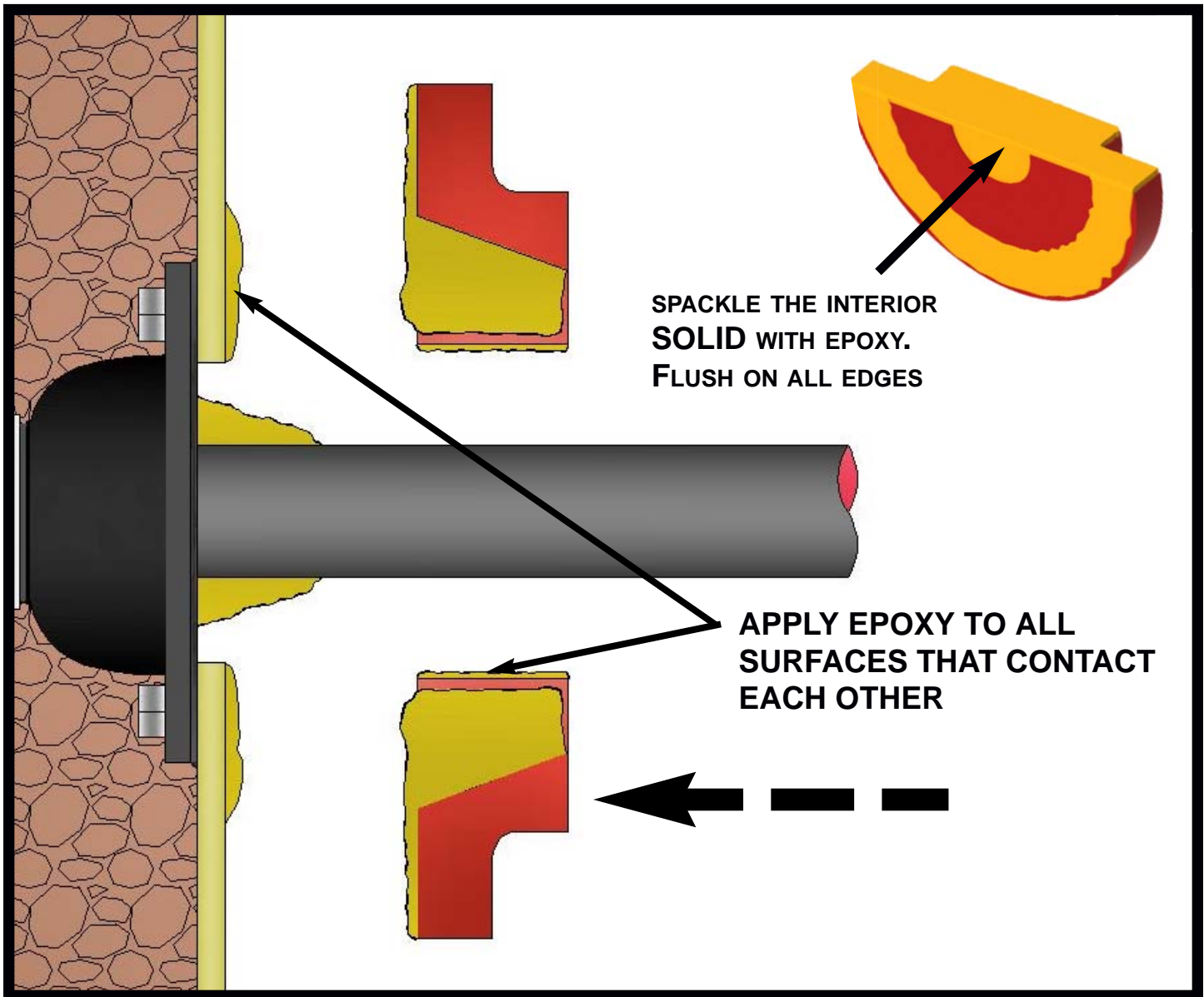

When only installing the body on flat walls, apply epoxy generously to all contact surfaces (including any flanges already on the wall), the pipe, interior of the fitting body, the surfaces of the fitting halves that will meet each other and the face of the body that will contact the curved flange or bare wall. Be generous on the interior, this is an area where a large amount of epoxy is critical. You need to gap-fill any air pockets.

**EPOXY SHOULD BE PACKED HEAVY ON THE INTERIOR !
ENSURE THAT YOU HAVE FULL EPOXY CONTACT !**

STEP 8

COMPLETE

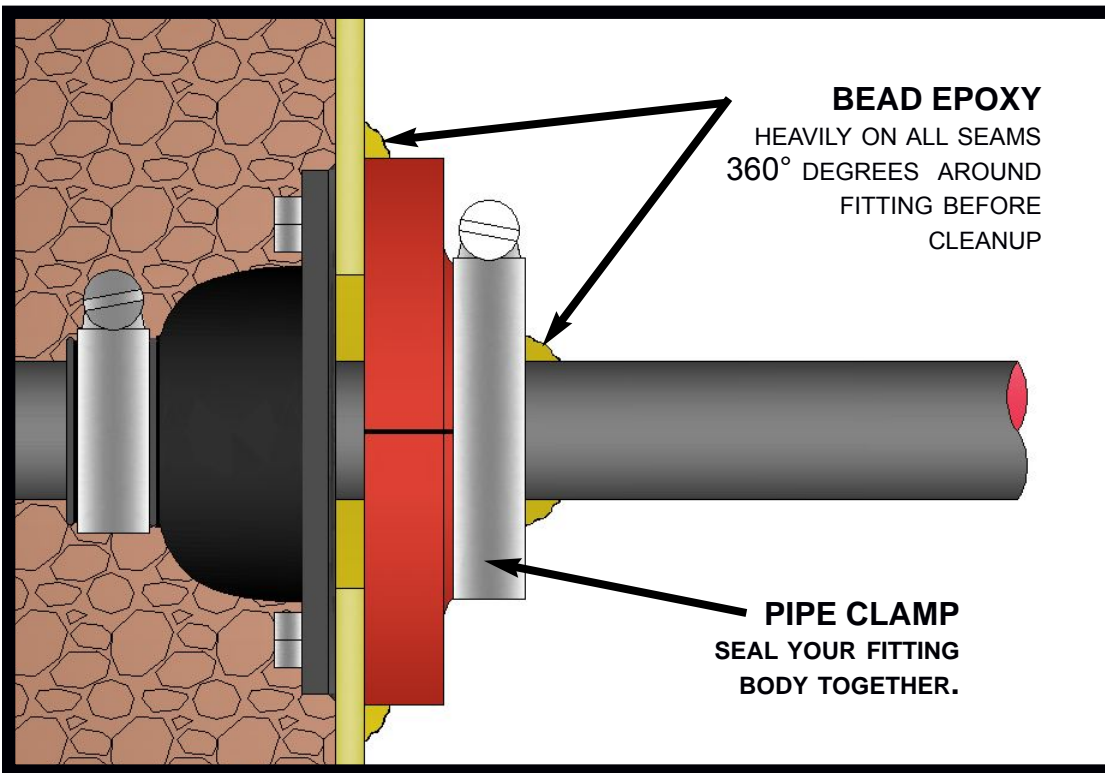

Stick this assembly to the wall and apply a strong pressure to push the halves together and against the wall. Epoxy should ooze from every seam and joint. Clean the face of the fitting with acetone or equivalent and remove excess epoxy. You want the fitting clean enough to remove the pipe clamp after the fitting cures.

Use provided pipe clamp to secure the fitting halves to each other. More epoxy may ooze from the split seams as you tighten, re-clean as necessary.

LET THE FITTING CURE **DO NOT ALLOW THE PIPE OR CONDUITS TO MOVE OR TWIST DURING THE CURE STAGE**

After a full cure, remove the pipe clamp holding the two fitting halves together. If it is too difficult to remove and appears to be bonded in place, do not force it off.

STEP 9

Water Testing:

COMPLETE

After the F-Series Retrofit-S Fittings are installed and have fully cured, water level test to a minimum of 2" above the highest penetration fitting on the sump. Follow local regulations.

If this Retrofit was installed to steel sumps:

Re-coat and corrosion-protect any exposed steel around the fitting area.