

# BRAVO FF-SERIES INSTALLATION INSTRUCTIONS

## SERIES PIPING OR SIZE OVER SIZE

BRAVO FIBERGLASS VALUE SERIES FOR RIGID SINGLE WALL SUMPS ONLY  
FIBERGLASS PIPE ONLY

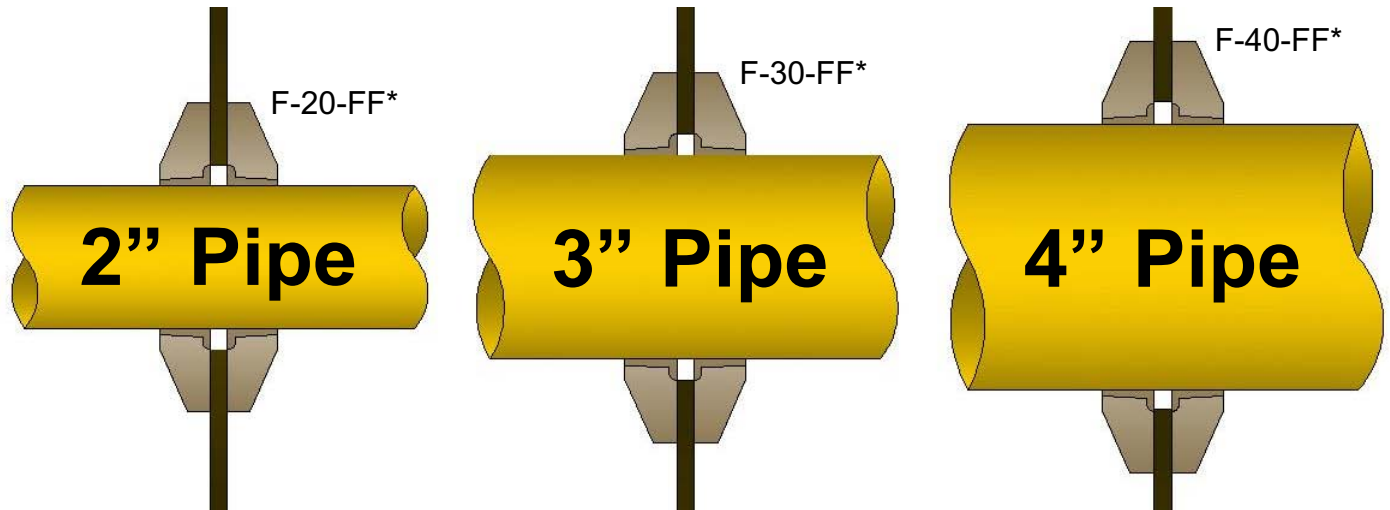

PRODUCT SPECS:			
Material . . . . .	UL Fiberglass		
PART #	Weight	Diameter	Allowed Angle
F-20-FF:	1 lbs	5"	5°
F-30-FF:	1.75 lbs	7"	5°
F-40-FF:	2 lbs	7.5"	5°

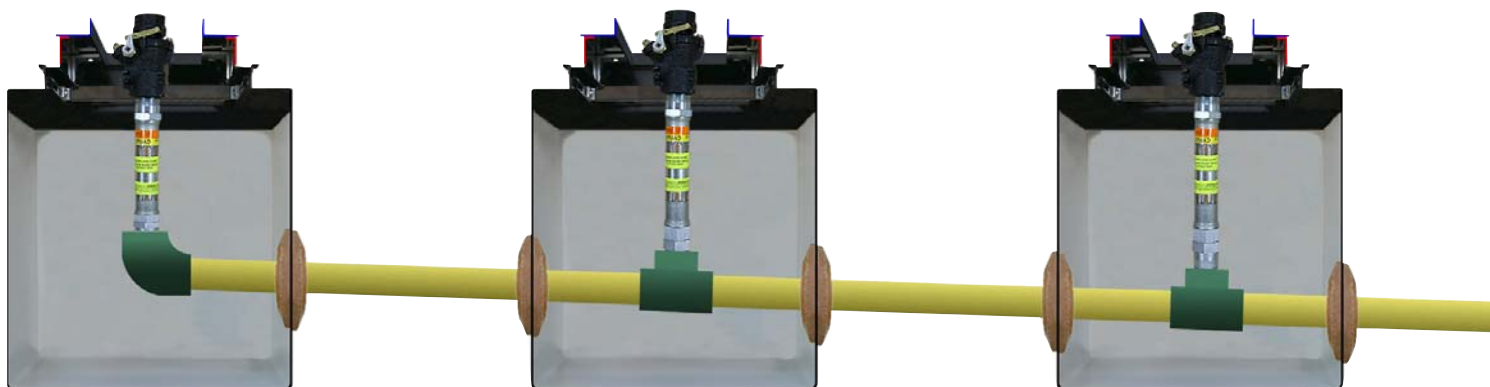

S. Bravo Systems, Inc.  
2929 Vail Ave. - Commerce, CA 90040  
(323) 888-4133 - FAX: (323) 888-4123  
[www.SBravo.com](http://www.SBravo.com)



\*Actual products may vary in appearance

Written by Jonathan Smith

# IMPORTANT

It is **HIGHLY RECOMMENDED** that the F-Series SingleWall Fiberglass Flange Fittings be installed by a **Bravo Certified Contractor**.  
**CERTIFICATION IS NOT REQUIRED!**

The FS Test will prepare you at [www.sbravo.com/cert.htm](http://www.sbravo.com/cert.htm)

## REQUIRED TOOLS (NOT PROVIDED)

Trichlorethylene or Acetone. Hole saw, 3", 4" & 5" diameters. 1/4" Drill bit.

**Approved Adhesives:** Smith™ 8014, 7014, 8069 or 7069. Ameron™ PSX-20

CLAMPS FOR FITTINGS	2" pipe.....T-FF-CLAMP-2	(set of two)
	3" pipe.....T-FF-CLAMP-3	(set of two)
	4" pipe.....T-FF-CLAMP-4	(set of two)

# IMPORTANT

**READ THESE INSTRUCTIONS - KEEP FOR FUTURE REFERENCE**

## TABLE OF CONTENTS

WARRANTY INFORMATION.....p. 3  
 A) Preparing the Fitting and Fiberglass Wall..... p. 4-5  
 B) Gluing your F-Series Assembly..... p. 6-7  
 C) Testing your F-Series Installation.....p. 7

*- Closely adhere to all directions and warnings indicated on the product or contained in these instructions.*

*- Warranty is void if there is any evidence of modification, abuse, negligence or improper installation.*

**If you have any problems with Bravo Systems components or accessories, Contact Bravo Systems Immediately:**

**1-800-28-BRAVO**

**1-323-888-4133**

**info@sbravo.com**

**SAFETY FIRST!** S. Bravo Systems, Inc. urges you to adhere to the normal safety procedures and precautions followed by your company. Please follow the mandates and compliances decreed by OSHA, local, State and federal regulations regarding the use of this product.

## WARRANTY

All containment systems sold by S. Bravo Systems, Inc. are warranted to be free from defects in material and workmanship for a period of one year from date of purchase. This warranty will be limited to the repair and replacement of Bravo parts only and will exclude all claims for labor or consequential damage. No other express warranties given and no affirmation of S. Bravo Systems, Inc., or its agents and/or representatives, by words or action, will constitute a warranty. IT IS EXPRESSLY AGREED THAT THIS WARRANTY WILL BE IN LIEU OF ALL WARRANTIES OF FITNESS AND IN LIEU OF THE WARRANTY OF MERCHANTABILITY.

This warranty is void if there is any evidence of modification, abuse, negligence, or improper installation. If any fittings or components, other than S. Bravo Systems approved fittings or components, are used in conjunction with any S. Bravo Systems product, the warranty pertaining to these products is immediately void.

## Included Parts (Per fitting)

- A) 2x Fiberglass F-Series Value Flange
- B) 2x 1.5 ounce bag of Fiberglass Filler for Adhesive
- C) 2x Pair of Industrial Nitrile gloves (Large)
- D) 1x 60 grit sand paper (not shown)
- E) 1x 10" long by 2" wide rubber strip (not shown)

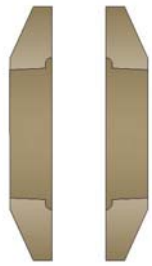

F-20-FF

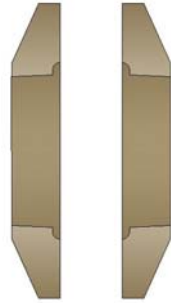

F-30-FF

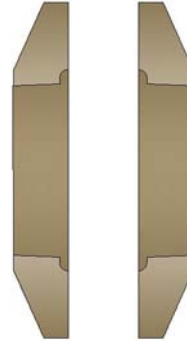

F-40-FF



Number of fittings that can be installed per Adhesive Kit

	Ameron 5 oz	Ameron 8 oz	Smith 6.5 oz	Smith 9.5 oz
F-20-FF	2	3	2	3
F-30-FF	1	1-1/2	1	1-1/2
F-40-FF	1	1-1/2	1	1-1/2



# WARNING



## WARRANTY IS VOID:

IF ANY OF THE FOLLOWING OCCUR

- A) Adhesive that is not Bravo-Approved is used to install the F-Series Value fittings.
- B) Installing Smith pipe with Ameron Adhesive or Ameron pipe with Smith Adhesive.
- C) F-Series Fiberglass Fittings are **NOT** installed per the directions in this manual.

# A) Preparing the Fitting & FRP wall

**A.1)** Prepare your fittings by identifying the parts. Clean the surfaces of all fittings with trichloroethylene or acetone to remove any contamination. Hand sand with 60-grit sandpaper if necessary. Do not lay them on dirt, water, debris or other contaminated surfaces. When dusting off, use a shop brush or compressed air. **Do not use rags, cloth or cloth-like material**

**▲ CRITICAL**

**DO NOT PLAN HOLE SAW CUTS ON UNEVEN SURFACES. FLAT PANELS ONLY. CAREFUL OF CORNERS AND EDGES.**

**IMPORTANT**

**YOU CAN NOT MOUNT FITTINGS ON ROUND SURFACES**

**A.2)** Dust off Sump walls (inside and out) and **drill your pilot holes** centered on the planned fitting locations using a 1/4" Drill bit. Proceed when done to cut your holes with appropriate size hole saw with 1/4" centralizer **ON ONE SIDE OF SUMP ONLY**. **See the table of fittings and hole saw sizes below**. Then measure and double-check your pipe angle if any, mark and cut opposite holes.

## **HOLE SAW SIZE CHART**

**3"** for F-20-FF Value Fitting

**4"** for F-30-FF Value Fitting

**5"** for F-40-FF Value Fitting

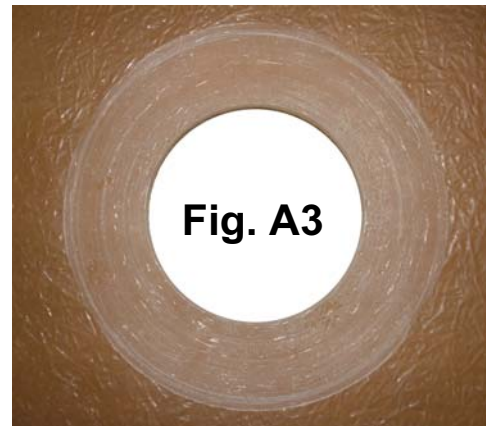

**A.3)** Hand-sand the rough edges inside and outside made by the hole saw and lightly abrade 2" out from each hole until the surfaces are flat and even, inside and outside (**Fig. A3**).

**DO NOT OVERSAND!! MAINTAIN A MINIMUM WALL THICKNESS OF 1/8" INCH**

**A.4)** You must rough up (hand sand) the area of the primary pipe (*product carrying pipe*) **One Inch (1")** away from the face of the flange, when dry fit, and all of the pipe between the two points.

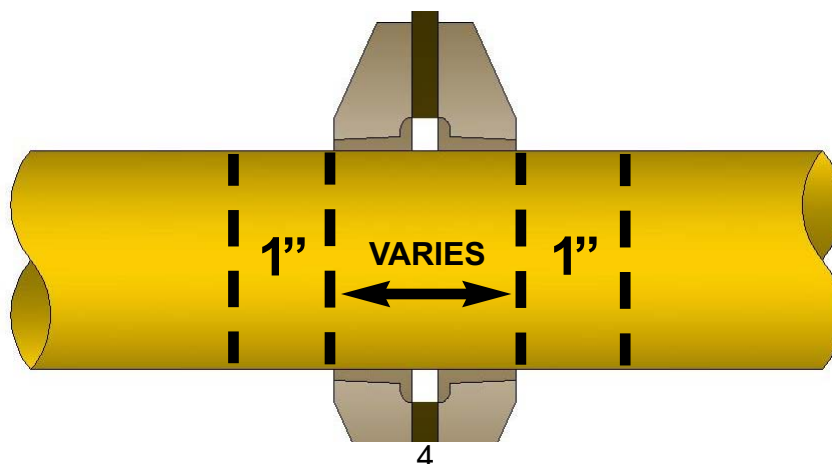

# ROUGHING-UP YOUR PRIMARY PIPE WITH SAND STRIP

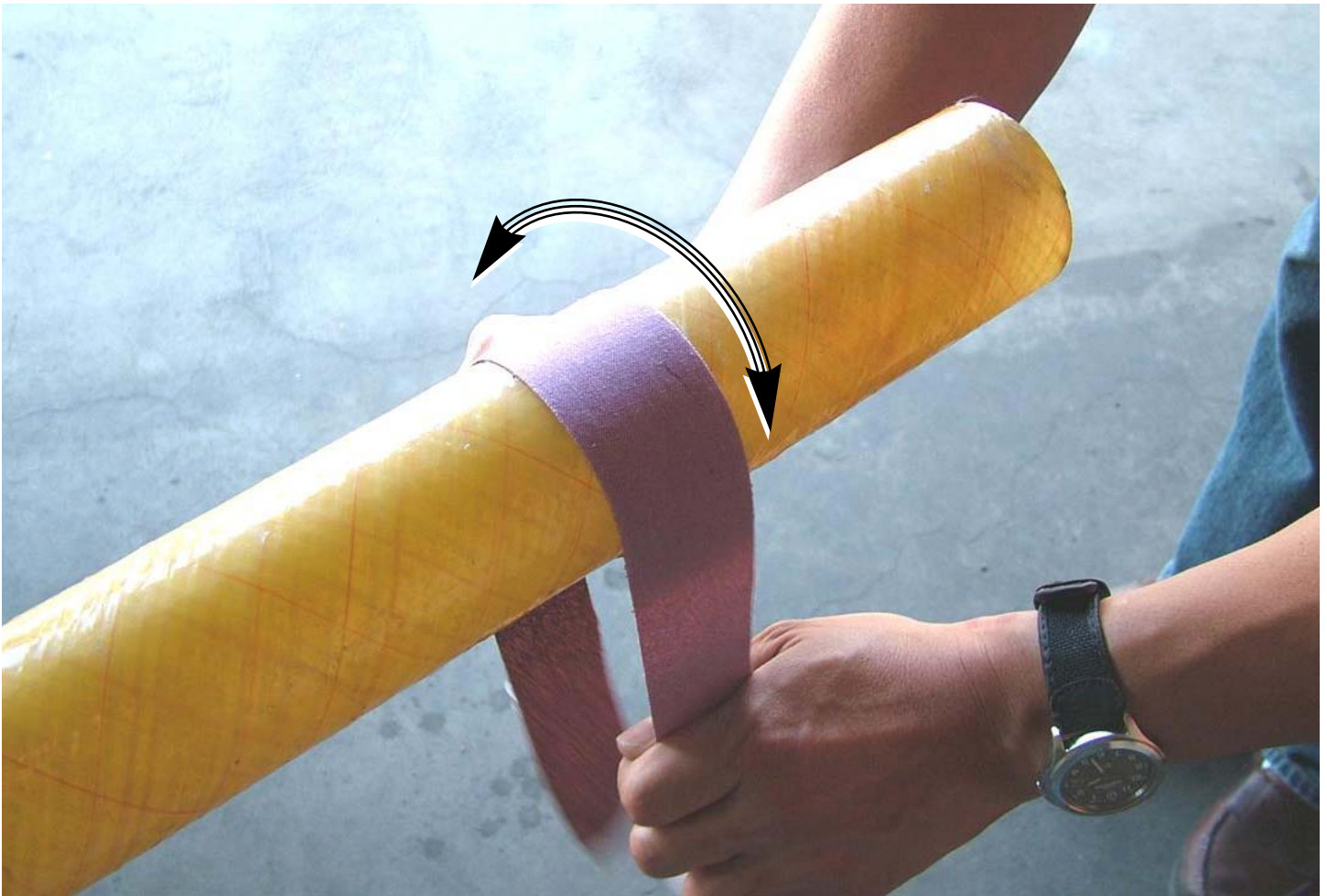

Your pipe must be hand roughed in preparation for Installation to the Bravo F-Series Value Fitting

## **B) Gluing your Fitting to Pipe**

**B.1)** Your pipe and Bravo FRP rigid penetration fittings should be clean and **COMPLETELY DRY AT ALL TIMES**. All pre-abraded or milled areas should be inspected for debris and inconsistencies. No dirt, grit, water or other foreign material should be on or inside the fiberglass fitting components.

**⚠ CRITICAL**

**USE PIPE MANUFACTURERS ADHESIVE ONLY**

**B.2)** Please follow your pipe manufacturers' installation guidelines on cleaning, cutting, scarfing, tapering and gluing your fiberglass pipe. Use a minimum of 4 feet between first joint & sump fitting for proper flexibility. Clean all parts after scarfing and tapering.

**B.3)** If size over size piping is used, you must use a pipe centralizer (Bravo part CTR-1 for 3"x2" pipe) between the primary and secondary pipe within 6" of the F-Series fitting, for each fitting.

**B.4)** **Dry-fit the flange fitting to the pipe on both sides of the sump wall. BOTH HALVES OF THE FITTING MUST BE PRESENT ON THE PIPE BEFORE GLUING YOUR PRIMARY.**

Seal all endpoints to your fiberglass pipe. **WRAP THE PROVIDED RUBBER STRIP AROUND THE PIPE TO PROTECT THE CUT EDGE OF THE SUMP WALL WHILE PRESSURE TESTING.**

Pressure test per local, state or federal codes.

**B.5)** Get one clamping set ready for each fitting. Clamps are sold separately.

**B.6)** Follow your adhesive manufacturer Instructions to mix and apply your adhesive.

**2 Bags of Filler  
per Adhesive Kit**



**DO NOT ATTEMPT TO MIX MORE THAN ONE KIT AT A TIME.**

Each fitting is supplied with Two 1.5oz bags of milled fiberglass. Mix using the chart to the right. Add more fiberglass filler to the adhesive at your own discretion if it seems too thin. Do not exceed twice the amount of filler to kit, per the chart above.

**B.7)** When all hole saw cuts have been made and piping has been tested with a **pass** result, apply a **GENEROUS** amount of adhesive to the wall, the fitting, inside the fitting cavity and to the pipe leading up to the wall for approximately 2 inches. (**Fig. B7**).

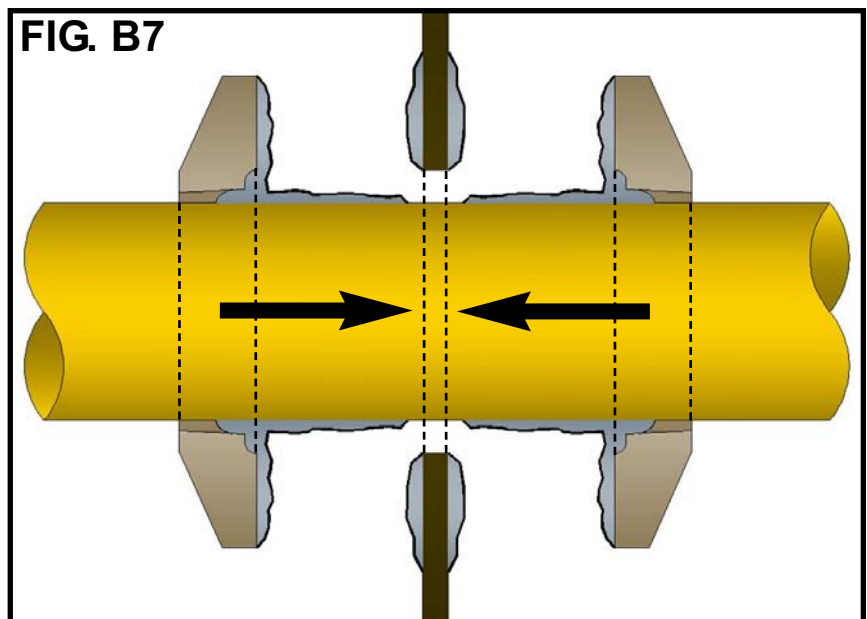

**B.8)** Push the two fitting halves together (**Fig. B7**) all the way to the wall. Use an adhesive brush to bead the adhesive and keep it from sagging or running off the fitting. Instead spread it around as thick as possible at the two Critical joints, 360°.

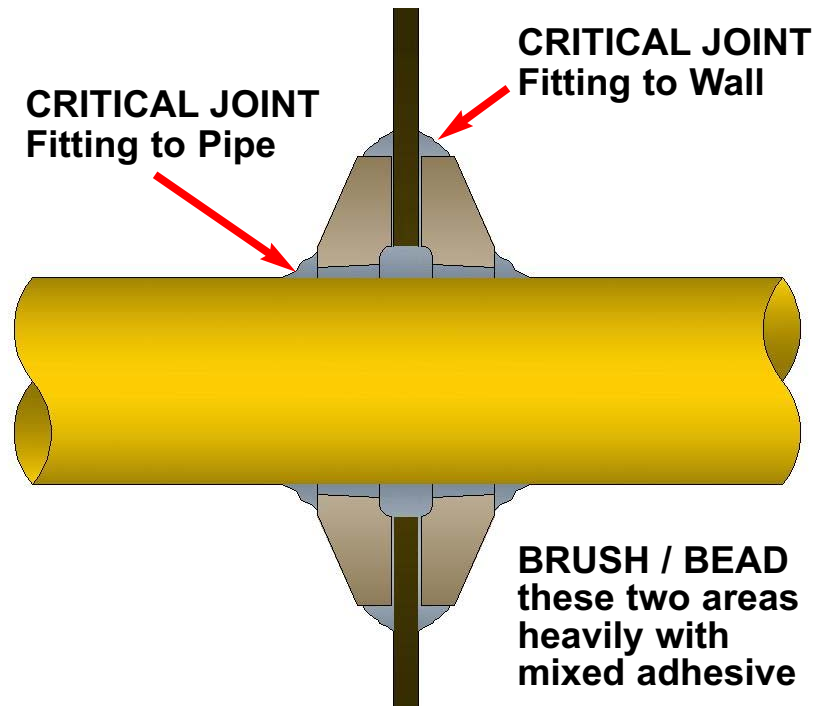

**B.9)** Apply the Bravo Clamp immediately following adhesive detail to each side of the pipe. Tighten the fitting to the pipe approximately 1" from the face and hand-tighten each thumb-screw so each bolt is evenly snug against the fitting. When both sides are snug then proceed to apply a 1/4 - 1/2 turn to each bolt evenly. The clamp should not slide along the pipe, nor should the pipe move into or away from the fitting.

**DO NOT TIGHTEN THE BOLTS ALL THE WAY.**

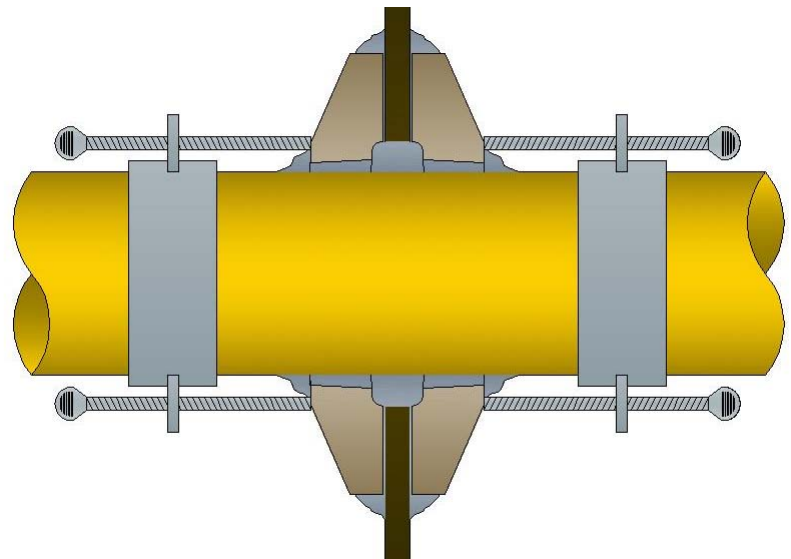

**B.10)** Glue all penetration fittings and allow to cure following the adhesive instructions.

## **C) TESTING YOUR F-SERIES INSTALLATION**

**C.1)** After all the F-Series Fiberglass Value Fittings on one Sump are installed and fully cured:  
**For SingleWall:** Bravo Sumps allows a water level test to a maximum of 2" above the highest penetration.