

INSTALLATION INSTRUCTIONS

B7000 REVOLUTION SERIES

SPLIT DISPENSER CONTAINMENT

FACTORY- PROVIDED

DISPENSER FRAME



1x Vulkem Sealant, 4x 1/2" bolts, 8x washers and 8x nuts are affixed to the Frame

PACKAGE FOR OPTIONAL EO



3x 3/4" clamps,
3x 1" clamps,
8x screw mounts
and 8x nuts

NYLON ROPE X2



TOOLS

(NOT PROVIDED)

Acetone, tools, safety equipment

REQUIRED

Standard Caulk Gun



S. Bravo Systems, Inc.
2929 Vail Ave. - Commerce, CA 90040
(323) 888-4133 - FAX: (323) 888-4123
www.SBravo.com

MANDATORY

The B-7000 Series Singlewall UDC from S. Bravo Systems, Inc. MUST be installed by a **Bravo Certified Installer**. Get Certified at www.sbravo.com/cert

IMPORTANT

READ THESE INSTRUCTIONS - KEEP FOR FUTURE REFERENCE

TABLE OF CONTENTS

A) Sump positioning & penetration fittings.....	p. 3
B) Sealing top to bottom sump.....	p. 4
C) Water testing sump joint and penetrations.....	p. 5
D) Concrete instructions for Electrical Offset.....	p. 6
E) Adjusting the product shear valve.....	p. 7

NOTICE

- Closely adhere to all directions and warnings indicated on the product or contained in these instructions.

- Warranty is void if there is any evidence of modification, abuse, negligence or improper installation.

- For assistance please call Bravo for technical support at (800) 28-BRAVO. Outside the U.S.A. please call (323) 888-4133.

SAFETY FIRST! S. Bravo Systems, Inc. urges you to carefully adhere to the normal safety procedures and precautions followed by your company. Please follow the mandates and compliances decreed by OSHA, local, State and federal regulations regarding the use of this product.

WARRANTY

All containment systems sold by S. Bravo Systems, Inc. are warranted to be free from defects in material and workmanship for a period of one year from date of purchase. This warranty will be limited to the repair and replacement of Bravo parts only and will exclude all claims for labor or consequential damage. No other express warranties given and no affirmation of S. Bravo Systems, Inc., or its agents and/or representatives, by words or action, will constitute a warranty. IT IS EXPRESSLY AGREED THAT THIS WARRANTY WILL BE IN LIEU OF ALL WARRANTIES OF FITNESS AND IN LIEU OF THE WARRANTY OF MERCHANTABILITY.

This warranty is void if there is any evidence of modification, abuse, negligence, or improper installation. If any fittings or components, other than S. Bravo Systems approved fittings or components, are used in conjunction with any S. Bravo Systems product, the warranty pertaining to these products is immediately void.

UPON ARRIVAL

Inspect your sumps for damage, which would be visible as bright white areas of fiberglass.

A) B7000 SUMP INSTALLATION

A.1) Assemble your B7000 Sump as a dry-fit only. First Bolt the dispenser frame to the top half of the sump and then tie the top half to the bottom with provided nylon rope. (**Fig. A.1**)

A.2) You should now determine your dispenser grade, run & secure a grade line.

A.3) With your island form in place, use angle stock (NOT Provided) to span the width of the island. Hang the UDC from the metal frame on both sides & secure it's position. Always set box at a minimum 1/4" above island level. **IF NO ISLAND WILL BE INSTALLED**, ensure the box is set at a minimum of 1" above grade. (**See Fig. A.3**)

A.4) Shovel a wide bed of peagravel under the UDC to support it fully.

A.5) Install your brackets, shear valves and flexes. Mark sump for penetration fittings.

A.6) Once the bed of peagravel is in place and the UDC is level and will not move, untie and lift the top half off. Set aside to allow easy access to interior for installation of penetration fittings.

A.7) Install all product Fittings and piping to the bottom Sump. Measure your fittings overall diameters. Using these measurements, plan your penetrations so that the fittings are 1" away from all edges and corners. **DO NOT WATER TEST**

A.8) The lower portion of the top is factory-abraded 3" up from the edge (**Fig. A1**). Prior to final installation (slurry mix and pour step) If it looks like this area has been contaminated, lightly hand sand with sandpaper and blow off with compressed air. If you are adjusting the height by cutting from the bottom of the top half, ensure that you re-abrade 3" up on the inside and outside.

A.9) SEALING TOP TO BOTTOM - Ensure the tongue and groove areas are completely dry, free of contamination and debris. Mix provided catalyst with the slurry mixture well and pour into the groove channel. Slowly lower top half into the channel and let slurry fully cure before testing.

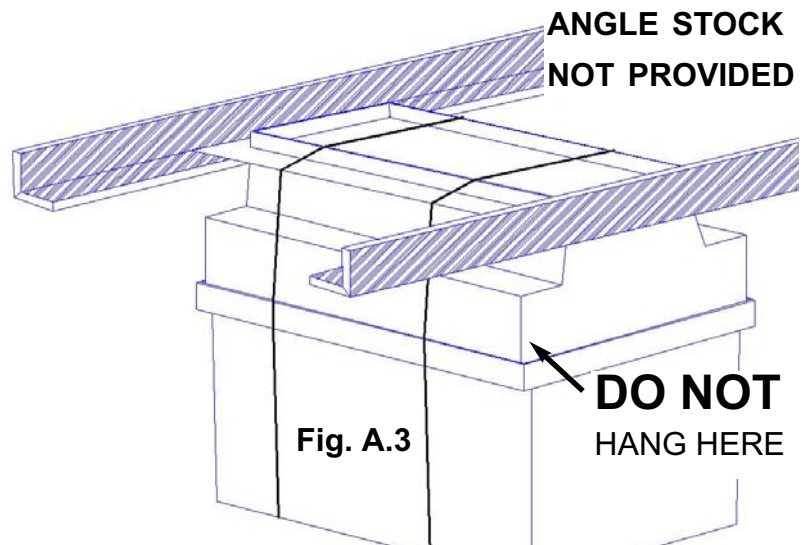
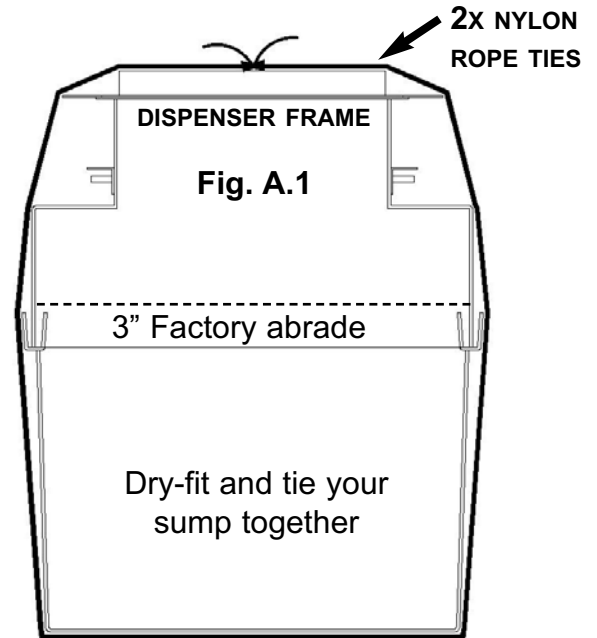

Rest Angle Stock across your island form to secure the assembled sump to the correct position and grade

B - SEALING TOP TO BOTTOM

⚠ CRITICAL SUMP MUST BE CLEAN & DRY **⚠ CRITICAL**

B.1 - Gather your **Slurry Kit** and tools. Ensure surfaces inside and outside of the channel and surrounding walls are clean of debris and **COMPLETELY DRY!** Verify tongue and groove areas are completely dry, free of contamination and debris.

⚠ WARNING    Wear protective goggles and a mask when mixing and applying resin or paste.

B.2 - DO NOT CATALYZE UNTIL SLURRY IS THOROUGHLY MIXED.

Pour entire can of slurry mix into your blue bucket and mix thoroughly for one minute. **THEN** add the catalyst and mix thoroughly again for one minute (**Fig. B.2a**). **Pour the slurry mixture into the groove channel** (**Fig. B.2b**). Use your stir stick to spread the slurry mixture around until it is even and level.



B.3 - Slowly and evenly lower the top half into the channel (**Fig. B.3**). **DO NOT SPILL ANY SLURRY BY MOVING THE SUMP TOP OR DROPPING IT INTO THE CHANNEL.**

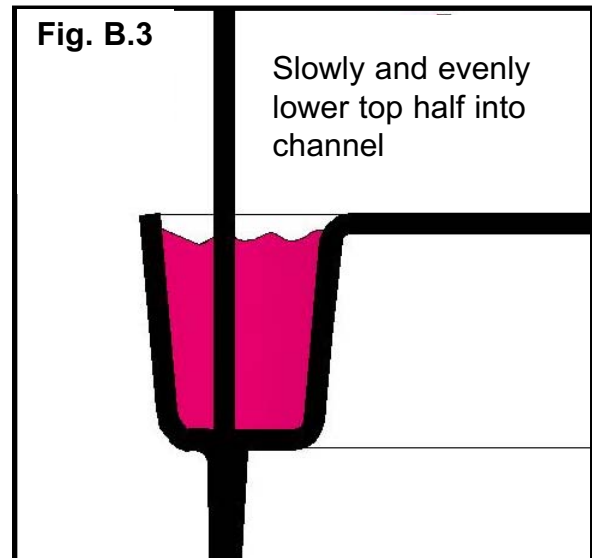
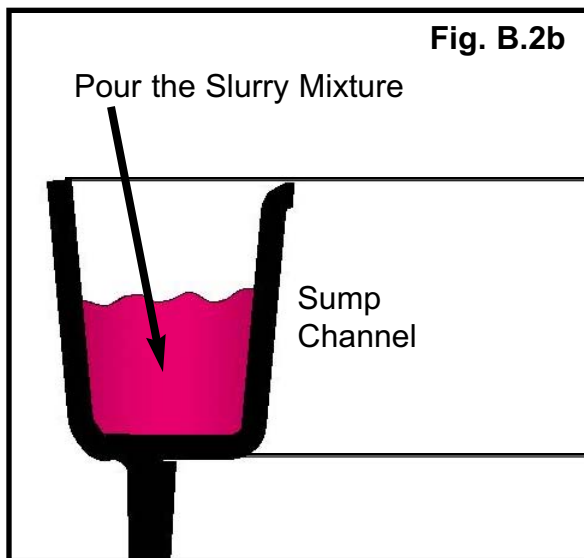

B.4 - OPTIONAL OVERSEAL - It is highly recommended that as a redundant seal for your B7000 Sump Joint, you cover and coat the top of the fully-cured slurry installation with Vulkem 116 polyurethane sealant on the outside only. If you choose to exercise this additional seal, you must thoroughly coat the top of the slurry within the channel so that the Vulkem smoothly seals to both the outside edge of the channel and the Sump wall, just above the fully cured slurry. **You can NOT use any other sealant type.**

NOTE: Vulkem 116 Sealant must cure Overnight.

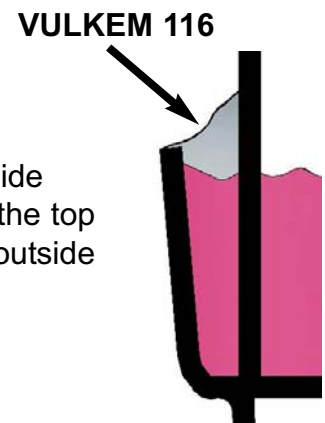

DO NOT HANG SUMP DURING WATER TESTING

C.1) To Water Test:

Sump must be supported from the bottom. Fill with water to no more than 2" above the sealed joint and monitor for one hour. Look for leaks at the sealed joint, fittings, and all edges and corners. If any leaks are found at the sealed joint OR on fiberglass walls, see **Step C.4** for repair instructions. **All local regulations precede these instructions.**

C.2) Seal any/all gaps between the fiberglass and the metal frame with Vulkem. Apply approximately 1/8" thick on the outside along the joint at the bottom edge of the frame, then seal any gaps from the inside as necessary. (**Fig. C.2**)

C.3) Install your Concrete Anchor Bolts to your dispenser frame as shown in **Fig. C.3**.

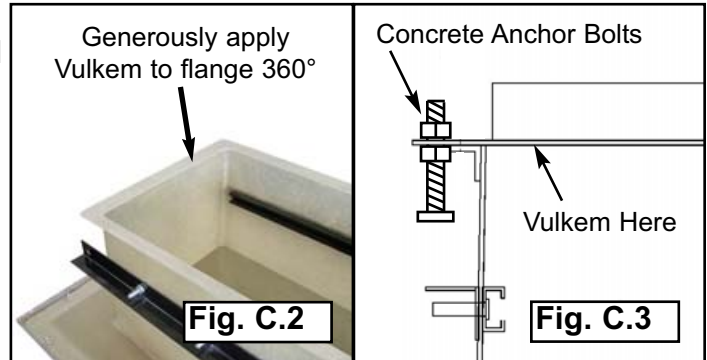

C.4) - Repair instructions for your sump, For Pinhole Leaks

Focus on edges, corners and All Penetrations. **For large leaks, consult factory.**

- A:** Locate leak point(s) and mark with marker so you can locate it / monitor it.
- B:** Repair or reinstall penetration fittings according to your penetration fitting manufacturers' Installation / Maintenance Instructions.
- C:** Abrade a 3" diameter area centered on the leak point until natural resin/fiberglass material can be seen. Dust with shop brush or compressed air and do not use shop towels or acetone on the abraded area(s). Then apply a 3-layer strip of 2" x 2" resin-saturated fiberglass mat squarely on the abraded area.
- D:** Roll out any air bubbles with a **chamfer roller**. Let cure.
- E:** After cure, knock down fiberglass hairs, and apply another flow coat of resin only. Let cure for a minimum of 4 hours @ or above 75° F.

ALLOW ANY REPAIRS TO FULLY CURE BEFORE TESTING SUMP AGAIN

C.5) Backfill your site with your available backfill material, in preparation of concrete pouring.

C.6) Re-Secure your Dispenser Frame to the island supports so that it will not interfere with your Concrete pour. When secure, proceed to pour concrete around UDC.

D) BRAVO ELECTRICAL OFFSET FRAME INSTALLATION INSTRUCTIONS

IMPORTANT

Make sure all electrical conduits and piping are clear of any equipment or other obstructions in the dispenser. Physically check your hydraulic cabinet for obstructions before any installation begins.

BRAVO UNDER DISPENSER CONTAINMENT ELECTRICAL OFFSET INSTRUCTIONS

D.1) The Frame should be fully installed and sealed with Vulkem before conduit installation.

D.2) Make sure all electrical conduits (piping) are clear of any equipment in the dispenser. Physically check your hydraulic cabinet for obstructions before any installation begins.

D.3) Conduits must be run and tightly secured to the sump.

D.4) Pour concrete around outside of Dispenser Sump per Bravo Installation Instructions.

Special Instructions:

D.5) You must Slope concrete within the Electrical Offset opening between the steel frame walls. This area **MUST** be sloped and **MUST** be sealed at the areas shown below.

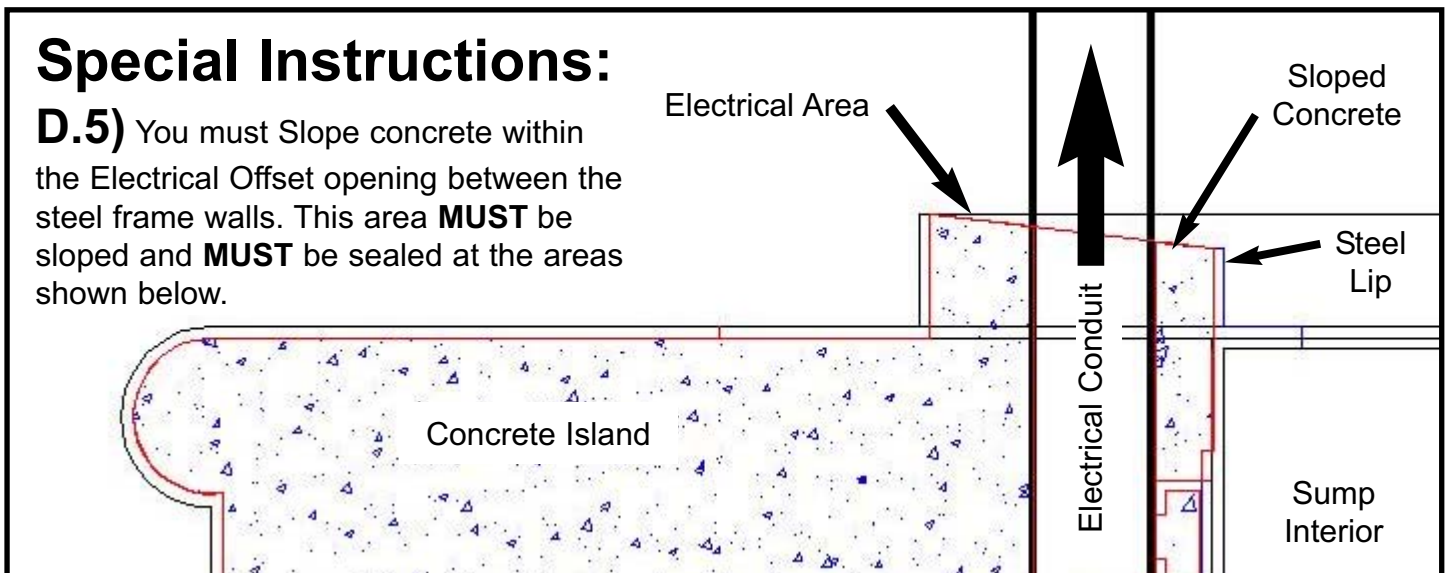

Special Instructions:

D.6) You must seal where concrete or conduit meets steel, as shown. Seal the downside of the slope and the conduit area with Vulkem 116.

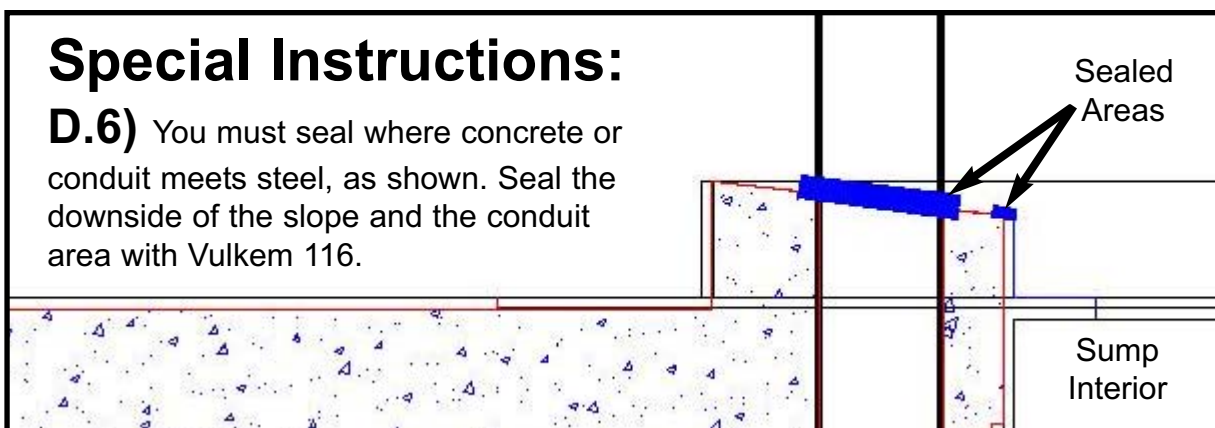

B7000 Revolution Series SingleWall Dispenser Containment

E - ADJUSTING THE PRODUCT SHEAR VALVE

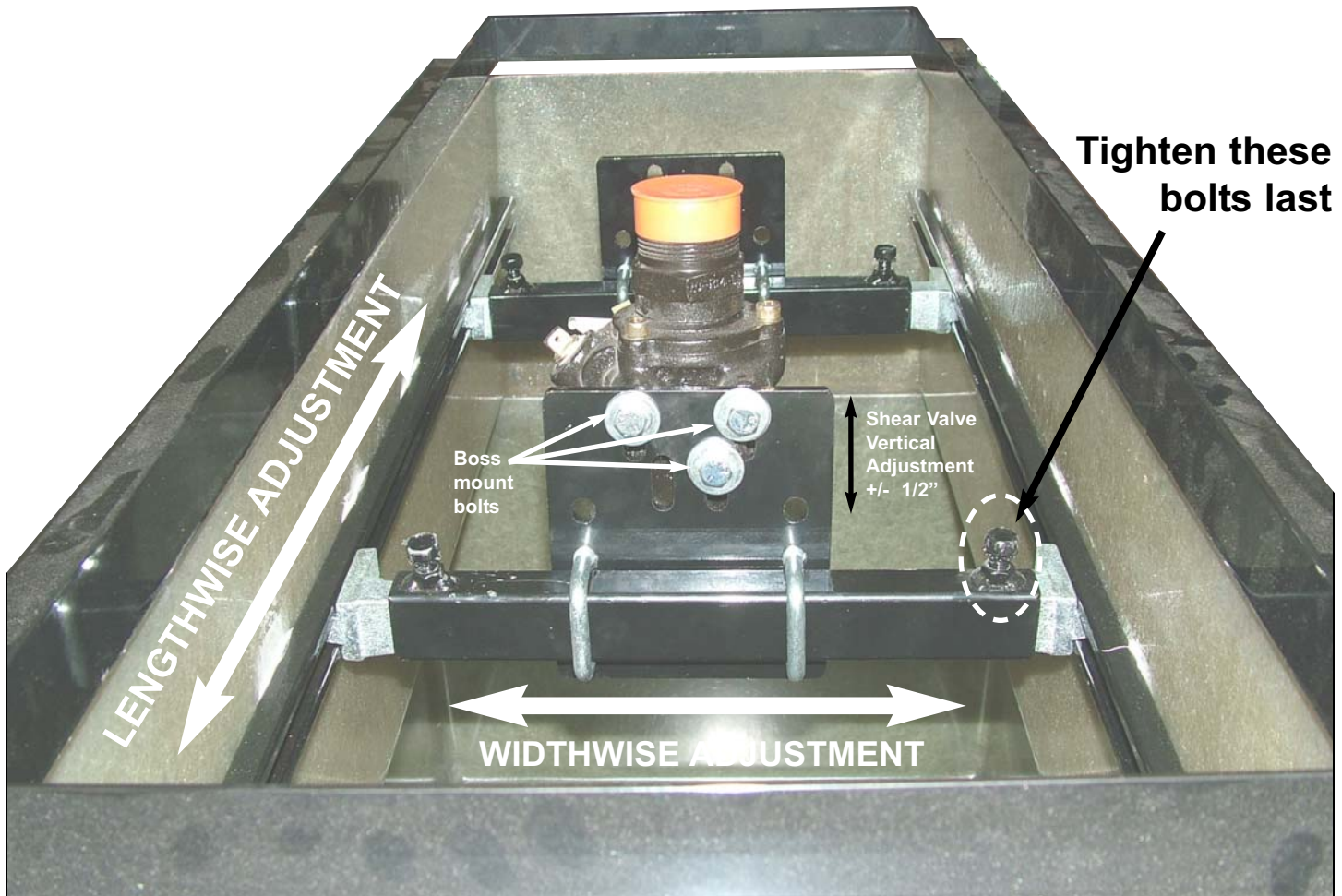

E.1 - When the dispenser is anchored properly, the dispenser inlet or pump inlet should be plumb with the product shear valve. If the product shear valves are positioned correctly, connect them with a union.

E.2 - If the valve and inlet are not aligned, determine the distance necessary for the valve to be moved. To adjust the valve lengthwise and/or widthwise, loosen the 3/8" bolts on the bracket ends and on the bracket inserts. Align valve to dispenser inlet and retighten bolts.

E.3 - Connect dispenser riser pipe to the product shear valve. A nipple may be required to extend the dispenser riser. If product shear valves are positioned correctly, connect them with a union.

IMPORTANT For rigid piping apply a UL classified pipe sealant for use and handling of gasoline and petroleum oils to externally threaded connections.

E.4 - Now retighten bolts and/or nuts attaching the shear valves to the bracket. Use provided washers. Tighten the top bolts for the brackets last, as this can restrict adjustability if tightened early.

E.5 - Connect electrical and vapor lines to the dispenser as required by local regulations. Always follow electrical and vapor component manufacturers' Installation Instructions.