

# B500-VRC / B600-VRC SERIES INSTRUCTIONS

## *DETAILS RS-500-VRC INSTALLATION*

SINGLE WALL VAPOR VENT / TRANSITION SUMPS



This document contains specialized instructions for installing the RS-500-VRC Structural Rack System designed for the Veeder Root Carbon Canister Vapor Polisher (CCVP) Enhanced Vapor Recovery System

For literature on this Veeder Root product, please visit:

[veeder.com/page/EVR\\_CARB](http://veeder.com/page/EVR_CARB)



**B-500-VRC**  
SINGLEWALLTRANSITION SUMP



S. Bravo Systems, Inc.  
2929 Vail Ave. - Commerce, CA 90040  
(323) 888-4133 - FAX: (323) 888-4123  
Info@SBravo.com - www.SBravo.com



# MANDATORY

The B-500/600 SingleWall Vent/Piping Transition Sump Series from S. Bravo Systems, Inc. **MUST** be installed by, and only by, **Bravo Certified Installation Contractors**. Details can be found at [www.sbravo.com/cert.htm](http://www.sbravo.com/cert.htm)

# IMPORTANT

## READ THESE INSTRUCTIONS - KEEP FOR FUTURE REFERENCE TABLE OF CONTENTS

A) Positioning the Vent Box..... p. 3  
 B) Penetration Fittings..... p. 3  
 C) Water Testing Transition Sump / Fittings..... p. 4  
 D) Repairing Leaks / Field Damage..... p. 4  
 E) Backfill, Concrete & Rack Installation Instructions..... p. 5

## REQUIRED TOOLS

(NOT PROVIDED)

Power/air Sanders. Acetone to clean up tools/applicators. Power Cutting Tools.

## RECOMMENDED

### FS-SAND-KIT

5/8" sanding disc backs and centralizers for all Bravo Systems Fittings



# NOTICE

- ***Closely adhere to all directions and warnings indicated on the product or contained in these instructions.***
- ***Warranty is void if there is any evidence of modification, abuse, tampering, negligence or improper installation.***
- ***For assistance please call Bravo for technical support at (800) 28-BRAVO. Outside the U.S.A. please call (323) 888-4133.***

**SAFETY FIRST!** S. Bravo Systems, Inc. urges you to carefully adhere to the normal safety procedures and precautions followed by your company. Please follow the mandates and compliances decreed by OSHA, local, State and federal regulations regarding the use of this product.

### WARRANTY

All containment systems sold by S. Bravo Systems, Inc. are warranted to be free from defects in material and workmanship for a period of one year from date of purchase. This warranty will be limited to the repair and replacement of Bravo parts only and will exclude all claims for labor or consequential damage. No other express warranties given and no affirmation of S. Bravo Systems, Inc., or its agents and/or representatives, by words or action, will constitute a warranty. IT IS EXPRESSLY AGREED THAT THIS WARRANTY WILL BE IN LIEU OF ALL WARRANTIES OF FITNESS AND IN LIEU OF THE WARRANTY OF MERCHANTABILITY.

This warranty is void if there is any evidence of modification, abuse, negligence, or improper installation. If any fittings or components, other than S. Bravo Systems approved fittings or components, are used in conjunction with any S. Bravo Systems product, the warranty pertaining to these products is immediately void.

# VAPOR VENT INSTALLATION INSTRUCTIONS

## A - VENT BOX POSITIONING

**A.1** - Determine the permanent position of the UniVent according to your site plans. Place the Vent Box lightly on a bed of compacted peagravel while you position it and make it level.

**NOTE:** Compacted Peagravel must be placed under and extended to the edge of the concrete profile. **See Page 5.**

**IMPORTANT** THE TOP OF ACCESS COVER (WHEN DRY - FIT) NEEDS TO BE:

FOR B500 VENT BOX - 2 INCHES ABOVE THE FINISH FLOOR

FOR B600 VENT BOX - 1 INCH ABOVE THE FINISH FLOOR

**A.2** - Using leveling stakes, stake the target area for vent box to be set and frame or scaffold the box into a permanent fixed position allowing access to front end of box for penetration fitting installation and to prevent any shifting or movement prior to pouring of concrete. (Fig. A.2)

**IMPORTANT** MAKE SURE VENT BOX IS PLUMB VERTICALLY AND LEVEL FOR CLEAN RACK SYSTEM INSTALLATION.

## B - PENETRATION FITTINGS

**B.1** - Remove Access Cover from Vent Box, set aside. Install required number of penetration fittings ONLY (Fig. B.1).

**IMPORTANT** IT IS RECOMMENDED THAT YOU ABRADE THE SUMP WALLS FLAT WITH THE FS-SAND-KIT

**B.2** - Install the required number of electrical penetrations and connections.

**B.3** - Please refer to your pipe manufacturer's Installation Instructions to install your Primary piping and vent lines. (Fig. B.3)

**B.4** - The Compression Fittings are Factory Installed. The Compression Gasket is also pre-greased by the factory. When Installing vent risers you must fit the Compression Gasket over the pipe, (Fig. B.4) down onto the Compression Fitting, and thread over the Compression Nut. Use the Bravo Compression nut tool (Part No. WR-3) to torque down the compression nut 1/4 to 1/2 turns past hand-tight.

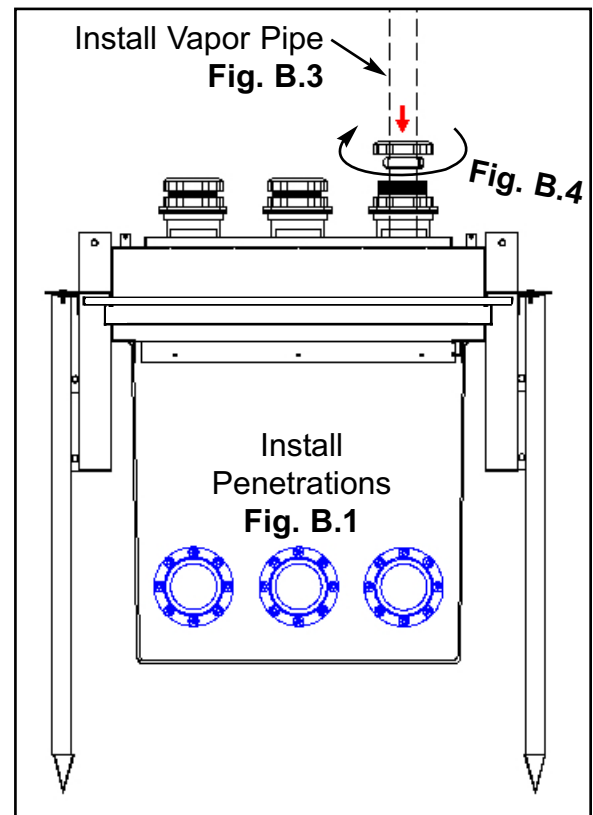
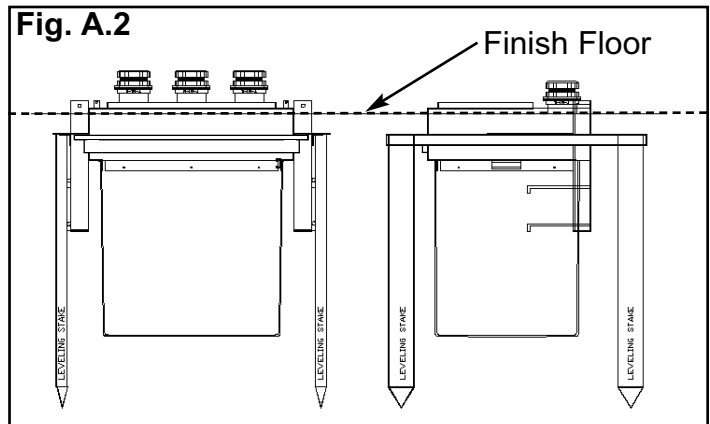

# C - WATER TESTING SUMP / FITTINGS

**IMPORTANT**

*It is recommended that all piping and conduits be connected at this time. Clear all debris & materials from the transition sump. All field installed penetration fittings must be water-leak tested.*

**C.1-** To test field installed fittings, add enough backfill under the Transition Sump so its weight is completely supported. Do not allow island supports to hold all the weight. The box will become extremely heavy.

**C.2-** Fill the box with water to **2 inches** above the highest fitting. **After 3 hours**, make a visual inspection of the exterior of the box. If there are no leaks, proceed to remove the water with an appropriate pump. **DO NOT DRILL A DRAIN HOLE**, and plan to patch the hole.

If there **ARE** leaks, proceed to **Step D** (below) for repair instructions.

## D - IF ANY LEAKS ARE FOUND!!

- A:** Locate leak point(s) and mark with marker so you can locate it / monitor it.
- B:** Repair or reinstall penetration fittings according to your penetration fitting manufacturers' Installation / Maintenance Instructions.
- C: Occasionally...** Bravo Fiberglass Series Products may suffer mild damage in transit or field installation. Please take a close look at edges and corners.
- D: FOR FIBERGLASS REPAIRS:** Abrade a 3" diameter area centered on the leak point until flow coat is gone and natural resin/fiberglass material can be seen. Dust with shop brush or compressed air and do not use shop towels or acetone. S. Bravo Systems recommends "**Smith Fibercast Adhesive Kit #8014**" to repair and reinforce Bravo Fiberglass products. Make sure area is completely dry and apply resin generously. For anything larger than pinhole leaks you must consult the factory.  
  
**FOR PENETRATION FITTING LEAKS/REPAIRS:** Follow penetration fitting manufacturers repair recommendations in their respective Installation Instructions. **DO NOT** compromise Bravo Product Integrity.
- E:** Let cure for a minimum of 2 hours @ or above 75° Fahrenheit.

## E - Backfill and Pouring the Concrete

**IMPORTANT**

Do not remove Square caps from Rack sleeves until after concrete has been poured and firmly set.

**E.1** - Backfill with peagravel around Vent Box, B500 should be set **2" above finish floor**. B600 should be set **1" above finish floor**. For each, the concrete should slope away from the top edge of the metal body. **Fig. E.1**.

**CAUTION**

**DANGER**

BRAVO SYSTEMS STATES INSTALLING PERMANENT "BOLLARDS" (HEAVY POSTS) IS:

**HIGHLY RECOMMENDED** if Vent Transition Sump is used for Vapor Vent Transition

**MANDATORY!** if Vent Transition Sump is used for Product Transition

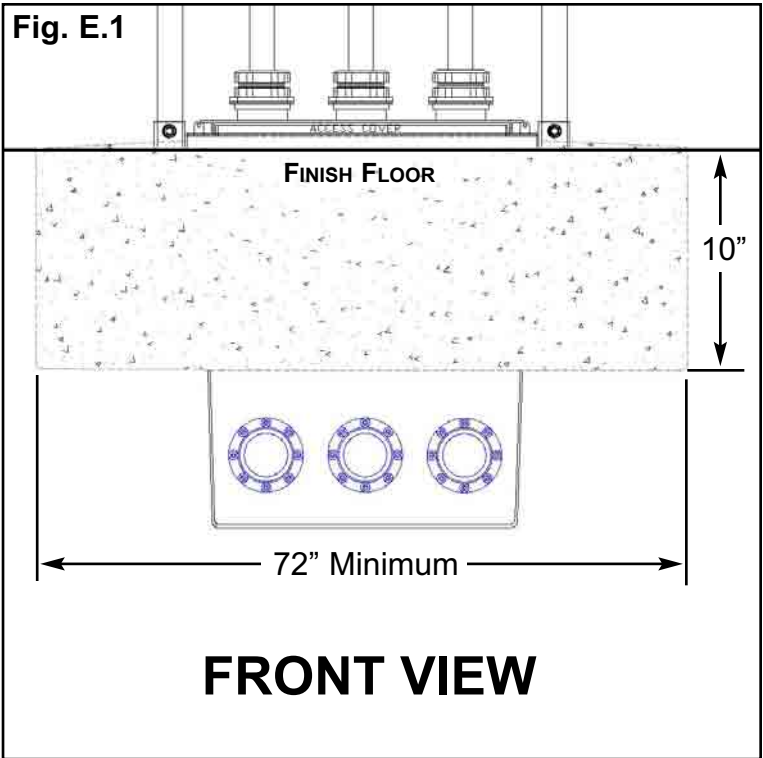

**Fig. E.3**

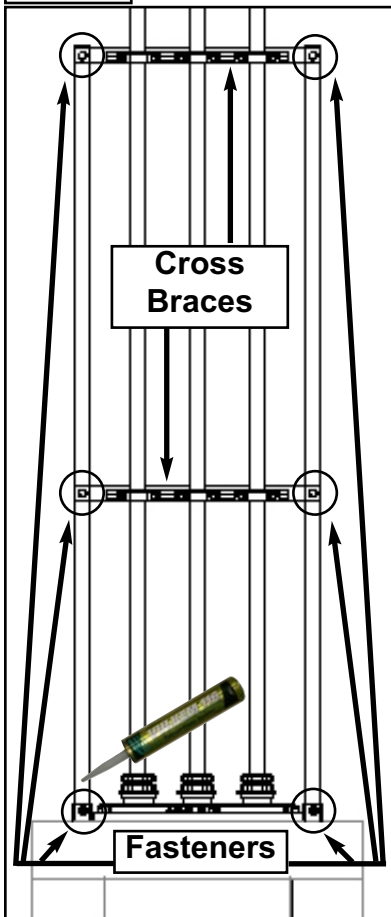

**E.2** - The concrete **MUST BE A 2500 PSI MIXTURE** and be poured to extend 10" down from the finish floor.

**E.3** - After concrete has set, remove square caps from rack sleeves and assemble rack system. Drop the rack system (RS500-VRC) into square tubing (or rack sleeves) secure, and seal off rack cross/brace and fasteners with Vulkem Sealant. (**Fig. E.3**)

**E.4** - Install vertical riser pipe to appropriate height, according to your local regulatory requirements. Secure pipes using pipe clamps to the rack system.

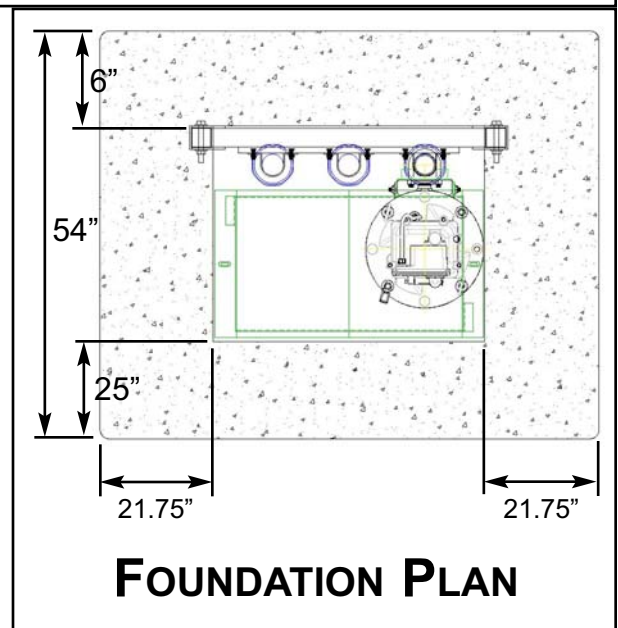

# VEEDER CARBON CANISTER VAPOR POLISHER INSTALL

Follow Manufacturer's Installation directions.

For installation documentation on this unit, please visit: [www.veeder.com/page/evr\\_carb](http://www.veeder.com/page/evr_carb)

**E.5** - After your vent risers (piping) has been installed and securely installed to the rack, mount your CCVP bracket to the appropriate riser pipe.

**E.6** - Two heights are critically important to this product.

**#1)** Height of lowest U-bolt on CCVP Bracket system to the top of Bravo Rack System (RS500-VRC)

**This distance must not exceed 18-3/4". See Fig. E6.1**

**#2)** Height of CCVP Unit on the Bravo Rack System (RS500-VRC)

**This distance must not exceed 156" from Finish Floor to the center of the Canister body. See Fig. E6.2**

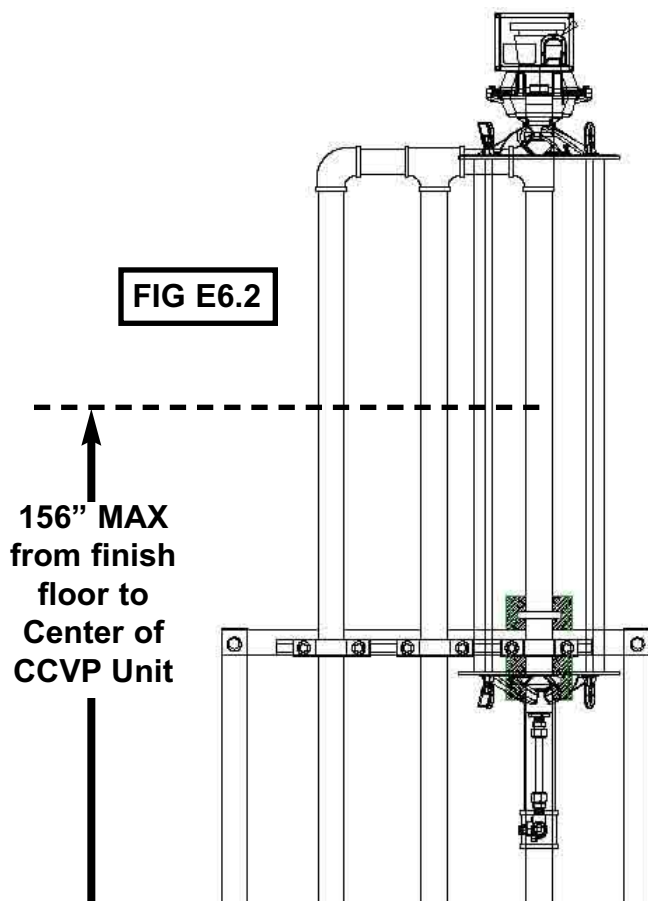
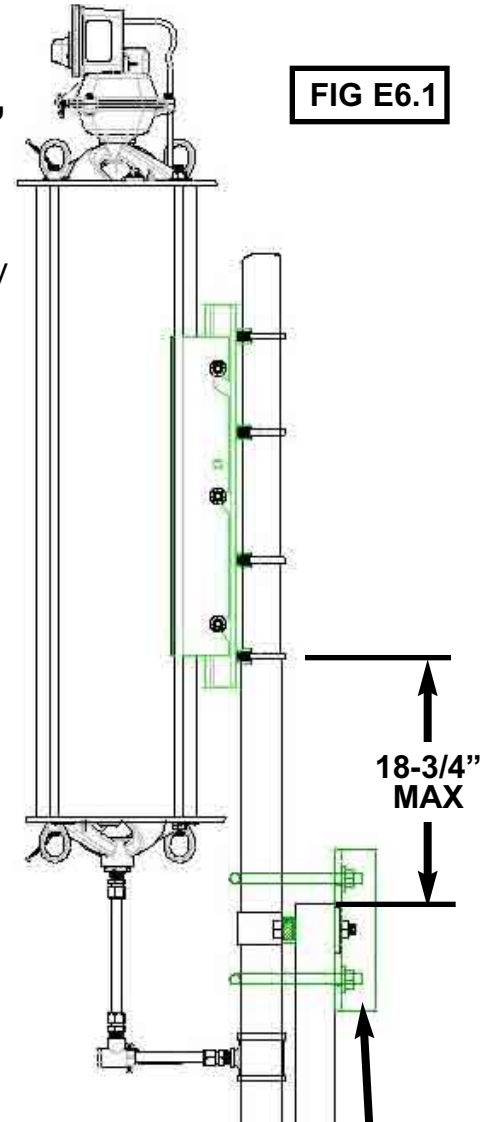

## **E.7** - STRUCTURAL CHANNEL

*After Risers have been fastened to the C-Channel on the Cross Brace:*

- 1) Hand fasten 1/2" U-Bolts to structural Channel.
- 2) Place insert into C-Channel that is attached to the Cross Brace.
- 3) Torque 1/2" U-Bolt nuts to evenly apply pressure to secure the pipe.