

# ***INSTALLATION INSTRUCTIONS*** ***B-TBF (TANK BUNG FITTING)*** ***FOR SINGLEWALL TANK SUMPS***



S. Bravo Systems, Inc.  
2929 Vail Ave. - Commerce, CA 90040  
(323) 888-4133 - FAX: (323) 888-4123  
[www.SBravo.com](http://www.SBravo.com)



ii-B-TBF-10A

# MANDATORY

The B-TBF Tank Bung Fitting from S. Bravo Systems, Inc. MUST be installed by a **Bravo Certified Installer**. Get Certified at [www.sbravo.com/cert](http://www.sbravo.com/cert)

*- Closely adhere to all directions and warnings indicated on the product or contained in these instructions. This includes following the OTHER manufacturers recommendations and Installation guidelines including -but not limited to- equipment associated or in contact with, Bravo Systems Products.*

*- Warranty is void if there is any evidence of modification, abuse, negligence or improper installation.*

*- For assistance please call Bravo for technical support at (800) 28-BRAVO. Outside the U.S.A. please call (323) 888-4133.*

**SAFETY FIRST!** S. Bravo Systems, Inc. urges you to carefully adhere to the normal safety procedures and precautions followed by your company. Please follow the mandates and compliances decreed by OSHA, local, State and federal regulations regarding the use of this product.

## WARRANTY

All containment systems sold by S. Bravo Systems, Inc. are warranted to be free from defects in material and workmanship for a period of one year from date of purchase. This warranty will be limited to the repair and replacement of Bravo parts only and will exclude all claims for labor or consequential damage. No other express warranties given and no affirmation of S. Bravo Systems, Inc., or its agents and/or representatives, by words or action, will constitute a warranty. IT IS EXPRESSLY AGREED THAT THIS WARRANTY WILL BE IN LIEU OF ALL WARRANTIES OF FITNESS AND IN LIEU OF THE WARRANTY OF MERCHANTABILITY.

This warranty is void if there is any evidence of modification, abuse, negligence, or improper installation. If any fittings or components, other than S. Bravo Systems approved fittings or components, are used in conjunction with any S. Bravo Systems product, the warranty pertaining to these products is immediately void.

# INSTALLATION COMPONENTS

## PROVIDED

1 TANK BUNG FITTING (B-TBF)  
1 pair of gloves. 1 sheet sandpaper.  
1 Tube of White Vulkem Polyurethane Sealant.  
2 bags of milled fiberglass filler.

## NOT PROVIDED

Air Sanders & drills. Acetone.  
5-1/2" Hole saw. Manual caulk gun.  
Bravo Tools: **CLAMP-TBF & SAND-TBF**  
**Smith Adhesive: #8014**  
**Ameron Adhesive: PSX-20**

# EQUIPMENT DRY-FIT

## BEFORE INSTALLING PENETRATION FITTINGS

# A - TANK BUNG FITTING INSTALL

**A.1** - Excavate backfill to expose the Tank Bung and remove riser pipe. Ensure that the threads of the Tank Bung are clean and undamaged. If it is a Fiberglass Tank, inspect the bung for damage or suspicious cracks, etc... Consult with Tank Manufacturer.

## IMPORTANT

**A.2** - To Install your Tank Bung Fitting to the Tank Bung, use a UL-Approved thread paste. Hand-thread until snug and then using 1-1/2" square tubing minimum 3' foot length, tighten down with a minimum torque of 200 ft-lbs to a maximum of 250 ft-lbs. (Fig. A.2)

**A.3** - GENEROUSLY SEAL ALL EXPOSED METAL THREADS - IF ANY - UNDER THE FITTING WITH VULKEM 116 SEALANT. (FIG. A.3)

If leaving overnight, cap the coupler or cover unit well with plastic.

**A.4** - Locate the point of penetration where you require the Tank Bung Fitting to be installed on the tank sump and use a 5-1/2" hole saw to cut the hole for the fitting. Dust off and clean up. Hand sand any rough or uneven areas.

**A.5** - You must sand the surface of the Tank sump around the cut hole **inside and outside**. Use an air grinder to ensure that a **2" area away from the cut hole** is abraded and that all paint, coatings or resin gloss is removed so that exposed fiberglass can be seen clearly. (Fig. A.5)

To ensure a high-quality fitting installation, Bravo Systems has a tool to help you grind this area absolutely flat. "**SAND-TBF**" is the part number for a sanding tool that mounts to a 5/8" arbor (drill). (Drill sold separately)

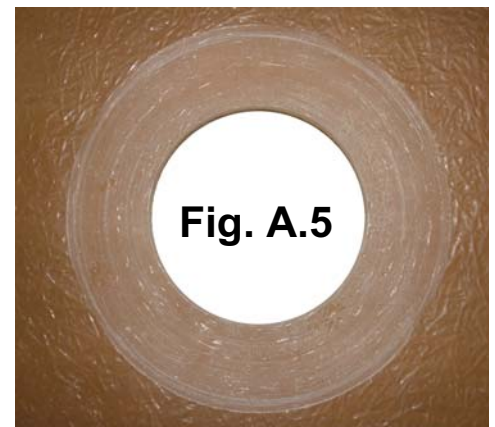
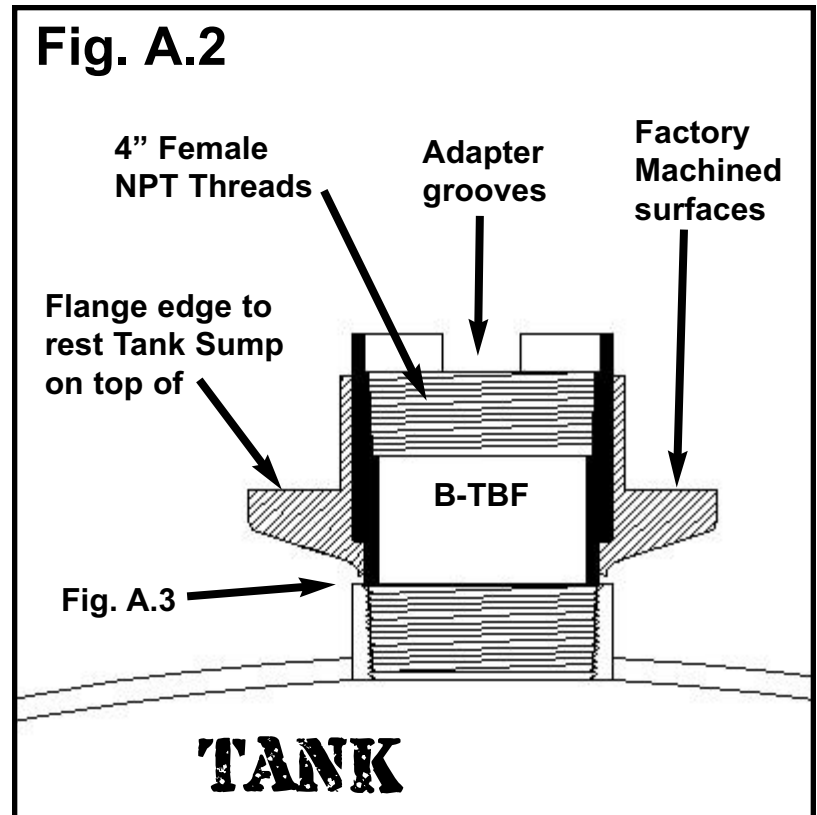

AREA AROUND HOLE SANDED ABSOLUTELY FLAT WITH SAND-TBF

**DO NOT OVERGRIND!! MAINTAIN A MINIMUM WALL THICKNESS OF 1/4" INCH**

**A.6** - Mix two bags of provided fiberglass filler per 8oz can of fiberglass adhesive and apply to the exposed flange face and side walls. (Fig. A.6)

**A.7** - Place the prepared Tank Sump slowly and gently onto the Tank Bung Fitting flange and turn into position.

Support the underside of the Tank Sump fully with a bed of peagravel. Shovel backfill under the Tank Sump so that it will accomodate additional weight without tipping over.

**A.8** - Add more adhesive to the exposed fiberglass areas of the Tank Sump and fitting. (Fig. A.8)

**A.9** - Next fit the loose flange over the Tank Bung Fitting and press firmly.

**A.10** - Thread on the Bravo Tool "CLAMP-TBF" into the tank bung fitting, snug only. Thread down each bolt so that they press firmly and evenly against the loose flange (Fig. A.10a). Adhesive should ooze from the joints. Apply extra adhesive around these areas and make sure to build it up against all joints. (Fig. A.10b)

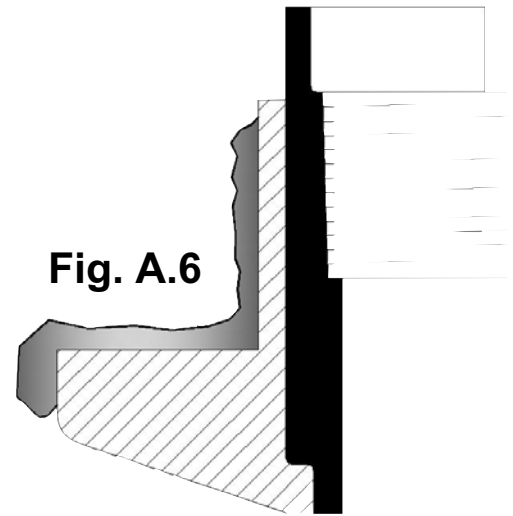

Fig. A.6

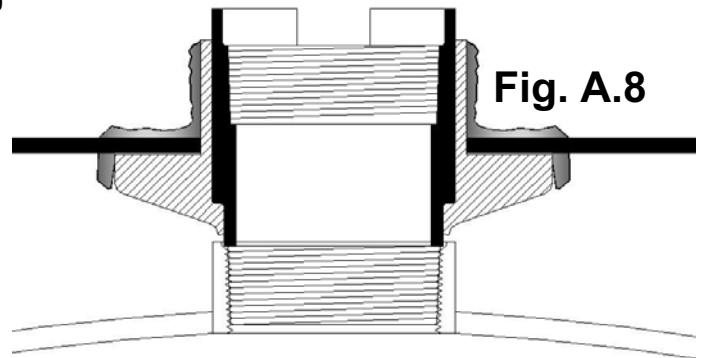

Fig. A.8

Allow for the maximum cure time at or above 75°F. Refer to adhesive manufacturers instructions.

**DO NOT DISTURB THE SUMP OR FITTING DURING THIS TIME**

Fig. A.10a

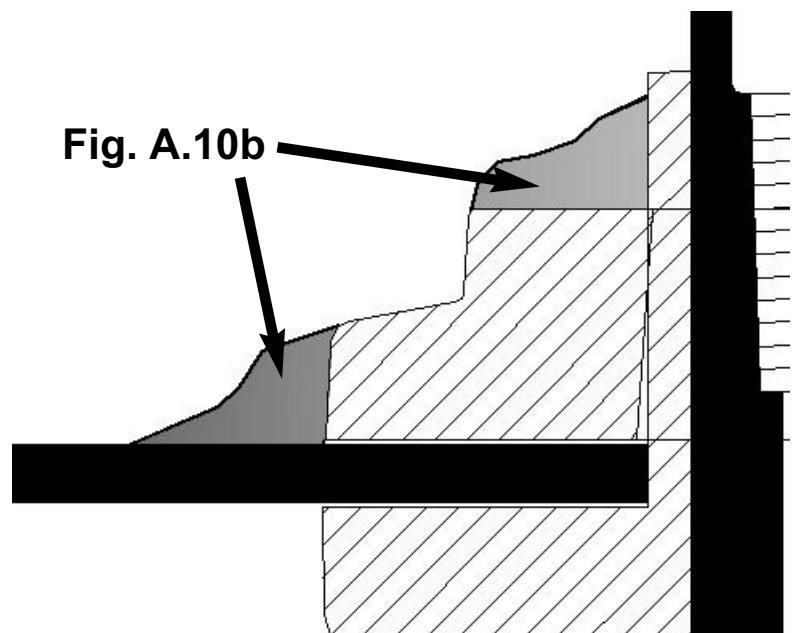
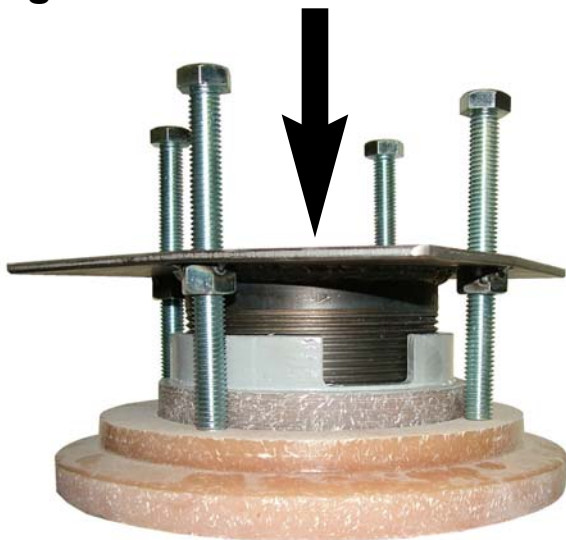

Fig. A.10b