

B-2000 INSTALLATION GUIDE AND MAINTENANCE INSTRUCTIONS

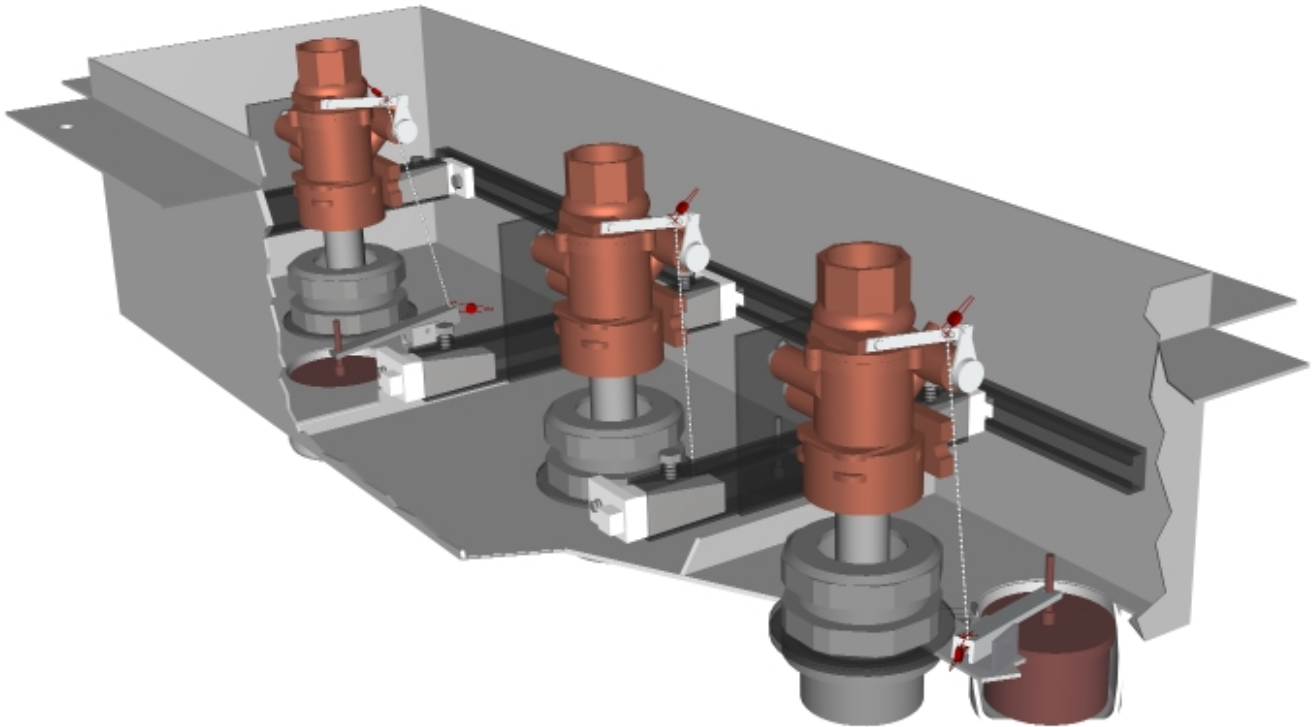

S. Bravo Systems, Inc.
2929 Vail Avenue • Commerce, CA 90040
(323) 888-4133 • FAX: (323) 888-4123
E-mail: info@sbravo.com • <http://www.sbravo.com>



IMPORTANT!

READ THESE INSTRUCTIONS • KEEP FOR FUTURE REFERENCE!

TABLE OF CONTENTS

NEW INSTALLATIONS	3
RETROFIT INSTALLATIONS.....	4
FIELD INSTALLED FITTINGS	5
DISPENSER INSTALLATIONS	6
MAINTENANCE INSTRUCTIONS	7

NOTICE

- *Adhere to all directions and warnings indicated on the product or contained in these instructions.*
- *The containment box should be installed only by a qualified contractor.*
- *Warranty is void if there is any evidence of modification, abuse, negligence or improper installation.*
- *For assistance please call Bravo for technical support at (800) 28-BRAVO. Outside the U.S.A. please call (323) 888-4133.*

SAFETY FIRST! S. Bravo Systems, Inc. urges you to carefully adhere to the normal safety procedures and precautions followed by your company. Please follow the mandates and compliances decreed by local and federal regulations regarding the use of this product.

WARRANTY

All containment systems sold by S. Bravo Systems, Inc. are warranted to be free from defects in material and workmanship for a period of one year from date of purchase. This warranty will be limited to the repair and replacement of parts only and will exclude all claims for labor or consequential damage. No other express warranties given and no affirmation of S. Bravo Systems, Inc., or its agents and/or representatives, by words or action, will constitute a warranty. IT IS EXPRESSLY AGREED THAT THIS WARRANTY WILL BE IN LIEU OF ALL WARRANTIES OF FITNESS AND IN LIEU OF THE WARRANTY OF MERCHANTABILITY.

This warranty is void if there is any evidence of modification, abuse, negligence, or improper installation. If any fittings or components, other than S. Bravo Systems approved fittings or components, are used in conjunction with any S. Bravo Systems product, the warranty pertaining to these products is immediately void.



S. Bravo Systems, Inc.
2929 Vail Avenue • Commerce, CA 90040
(323) 888-4133 • FAX: (323) 888-4123
E-mail: info@sbravo.com • <http://www.sbravo.com>



B-2000 Dispenser Containment NEW INSTALLATION

IMPORTANT: During installation, cover the B-2000 box with cardboard, plywood or other materials to avoid debris from falling into the box. Cover all threaded connections to protect threads from damage.

1. Determine the position of the box in the island and mark the center of the box (Fig. 3-A). Align box to the island and orient it properly. Note: containment boxes are marked "A" for junction box side; refer to dispenser manufacturer's junction box position.
2. As in Fig. 3-B, place angle stock across the island and position the B-2000 box in the island by resting the box flanges onto the angle stock. Secure the box to the island using 1/2" diam rebar. Run the rebar widthwise through the 5/8" diam holes on the legs of the box. Use tie wire to secure the box to the rebar. NOTE: remove the angle stock during the concrete finishing process. Alternatively, rebar can be placed lengthwise through 5/8" diam holes on the legs.
3. Insert 1/2" diam bolts through the top of the threaded anchor bolt holes. NOTE: pre-grease bolt threads to allow for removal when attaching dispenser. The bolts should be a minimum of 3" below box flanges. (Fig. 3-B).
4. At this time, only pour the island concrete. Note: remove angle stock when finishing island floor. **IMPORTANT:** do not pour the driveway slab. This will allow access for plumbing and electrical connections to the box.
5. After the island concrete has cured, remove the backfill from the side of the island. **IMPORTANT:** it is recommended that all piping and conduits be connected at this time. If field installed fittings are required, refer to page 5 for proper field installation of vapor and electrical fittings.

PRIMARY LINE INSTALLATION

6. Connect a UL approved flex connector and coupling to the bottom of the product line, using an approved sealant (Fig. 3-C). Always hold pipe or fitting while connecting flex connectors. Install and test entire primary line before attaching secondary lines. NOTE: rigid fittings may be used for primary and secondary line connections.

CAUTION: pressure test the primary line following the pipe manufacturers installation instructions. Shear valve assembly maximum test pressure is 75 psig. Refer to shear valve manufacturer's installation instructions for details.

SECONDARY LINE INSTALLATION

7. Install flexible hose, such as Bravo's (BFH-3) 3" diam flex hose, which isolates the flex connector. The B-18-3 fitting has a 3" secondary hose termination adapter (Fig. 3-D). Hold the B-18 fitting stationary while securing the threaded pipe end to the bottom of the fitting.

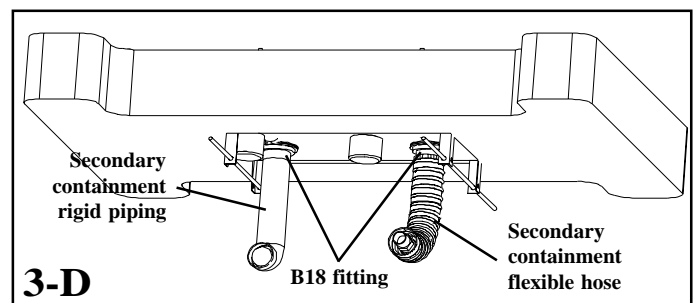
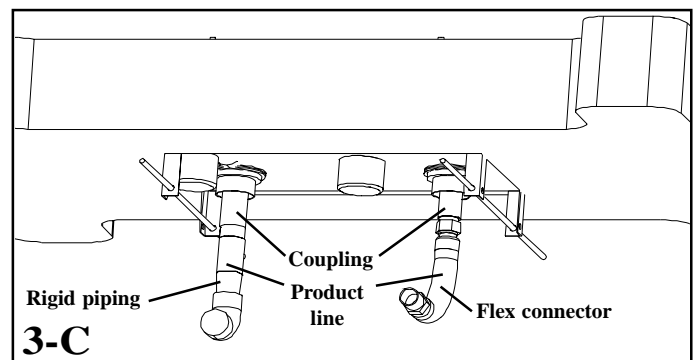
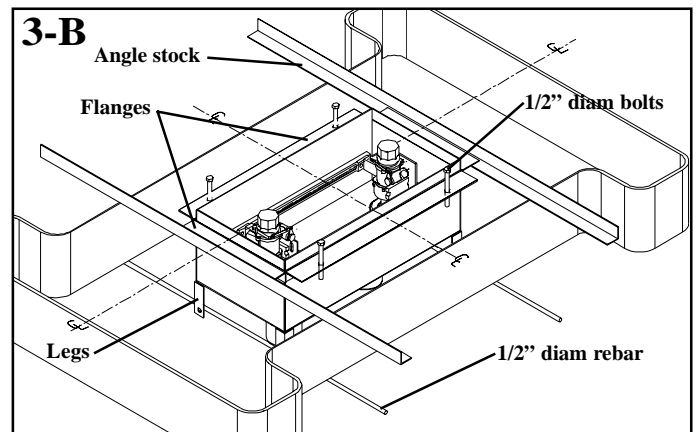
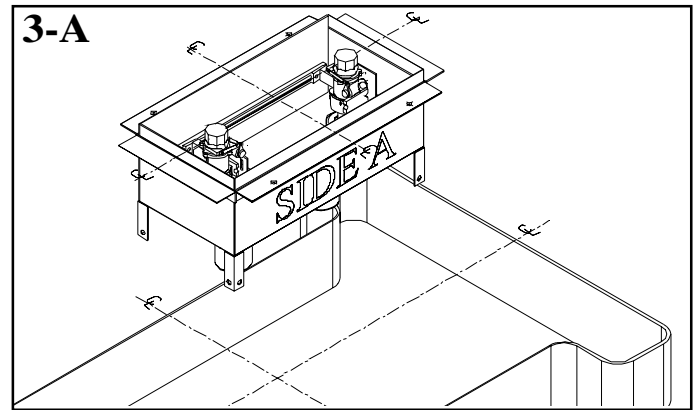

OPTIONAL: secondary piping may be terminated with 3" rigid pipe using Bravo's B-18-4 which has a 3" internal NPT adapter. **IMPORTANT:** for rigid piping, apply UL classified pipe sealant for use and handling gasoline and petroleum oils to the externally threaded end.

B-2000 Dispenser Containment

RETROFIT INSTALLATION

IMPORTANT: during installation, cover the B-2000 box with cardboard, plywood or other materials to avoid debris from falling into the box. Cover all threaded connections to protect threads from damage.

1. Shut off and disconnect all equipment. Remove dispenser(s).
2. Remove flange nuts from the B-2000 box (Fig. 4-A). Measure the length and width of the B-2000 box. Cut a hole in the island $\frac{1}{2}$ " wider and $\frac{1}{2}$ " longer than the box (Fig. 4-A).
3. Drop box in the island hole. Align box to the island and orient it properly (Fig. 4-B). **NOTE:** containment boxes are marked "A" for junction box side; refer to dispenser manufacturer's junction box position.
4. Using $\frac{1}{2}$ " diam concrete anchor bolts, independently attach the box frame to the island (Fig. 4-B). **IMPORTANT:** make sure the bolts do not interfere with the installation of the dispenser (Fig. 4-B).
5. **OPTIONAL:** install dispenser anchor bolts (Fig. 4-B). **NOTE:** anchor bolts may be installed after dispenser is replaced.
6. Place $\frac{1}{2}$ " diam rebar widthwise through the $\frac{5}{8}$ " diam holes on the legs and secure the box to the rebar with tie wire (Fig. 4-C). If there is space between island and rebar, reduce gap by wedging pressure treated wood. **IMPORTANT:** it is recommended that all piping and conduits be connected at this time. If field installed fittings are required, refer to page 5 for proper field installation for vapor and electrical fittings.

PRIMARY LINE INSTALLATION

7. Connect a UL approved flex connector and coupling to the bottom of the product line, using an approved sealant (Fig. 4-C). Always hold pipe or fitting while connecting flex connectors. Install and test entire primary line before attaching secondary lines. **NOTE:** rigid fittings may be used for primary and secondary line connections. **CAUTION:** pressure test the primary line following the pipe manufacturers installation instructions. Shear valve assembly maximum test pressure is 75 psig. Refer to shear valve manufacturer's installation instructions for details.

SECONDARY LINE INSTALLATION

8. Install flexible hose, such as Bravo's (BFH-3) 3" flex hose, which isolates the flex connector. The B-18-3 fitting has a 3" secondary hose termination adapter (Fig. 4-D). Hold the B-18 fitting stationary while securing the threaded pipe end to the bottom of the fitting.

OPTIONAL: secondary piping may be terminated with 3" rigid pipe using Bravo's B-18-4 which has a 3" internal NPT adapter.

IMPORTANT: for rigid piping, apply UL classified pipe sealant for use and handling gasoline and petroleum oils to the externally threaded end.

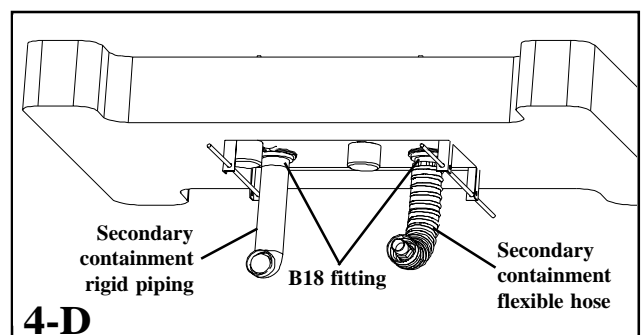
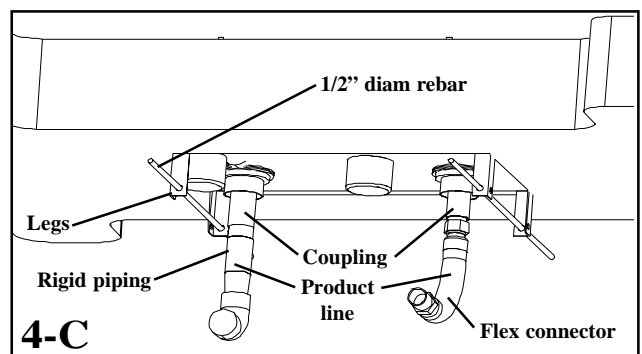
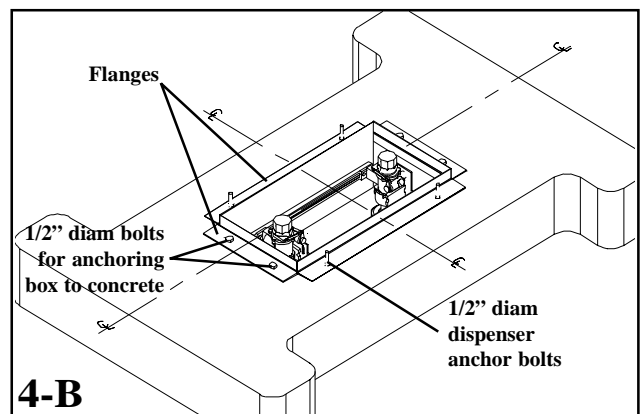
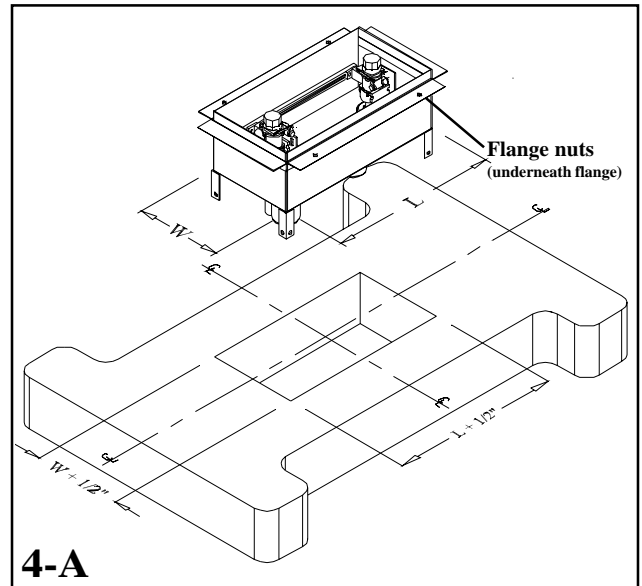

B-2000 Dispenser Containment

FIELD INSTALLED FITTINGS

NOTE: all surfaces should be as clean as possible prior to tightening any bulkhead fittings into place.

VAPOR RECOVERY PENETRATION FITTINGS INSTALLATION

NOTE: containment boxes are marked "A" for junction box side; refer to dispenser manufacturer's manual for appropriate vapor position.

1. On the bottom, inside the B-2000 box, locate the position of the vapor recovery line.
2. A 2-3/8" diam hole size is required for the B-27-SET-3 fitting. Cut the hole using appropriate tool. **CAUTION: make sure that there is adequate space for tightening the B-27-SET-3 fitting. Always follow proper safety procedures when cutting into steel.**
3. Clean the hole of sharp edges using round files. Remove locking nut and one gasket from fitting. Insert fitting flush with exterior of containment box.
4. Insert a gasket and a washer from the inside of the box until these are flush to the bottom of the box. Fasten the nut to the fitting. NOTE: The B-27 SET-3 fitting has a 3" secondary hose termination adapter. Rigid piping may be used for primary and secondary line connections. The B-27 SET-4 fitting has a 3" female threaded adapter for secondary rigid piping. Consult factory

ELECTRICAL PENETRATION FITTINGS INSTALLATION

IMPORTANT: electrical fittings are used to provide a continuous run to the electrical seal off. Containment boxes are marked "A" for junction box side; refer to dispenser manufacturer's manual for junction box position.

NOTE: electrical fittings such as Bravo's EBS fittings, are available for 1" and 3/4" conduit. For further information, consult your Bravo distributor.

1. On the bottom, inside the B-2000 Box, locate the position of the conduit. **CAUTION: make sure that there is adequate space for tightening the EBS fitting. Always follow proper safety procedures when cutting into steel.**
2. A 2" diam hole size is required for the EBS fitting. Cut the hole using an appropriate tool.
3. Clean the hole of sharp edges using round files. Remove electrical seal, locking nut and o-ring gasket from fitting. Insert fitting flush with exterior of containment box.
4. Insert o-ring gasket and a locking nut from the interior of the box until the fitting is flush to containment box. Fasten the nut onto the fitting.
5. Pass the electrical conduit through the EBS. Hose clamp the ES-1 to the EBS body and conduit.

VAPOR RECOVERY FITTING (B-27-SET-3)

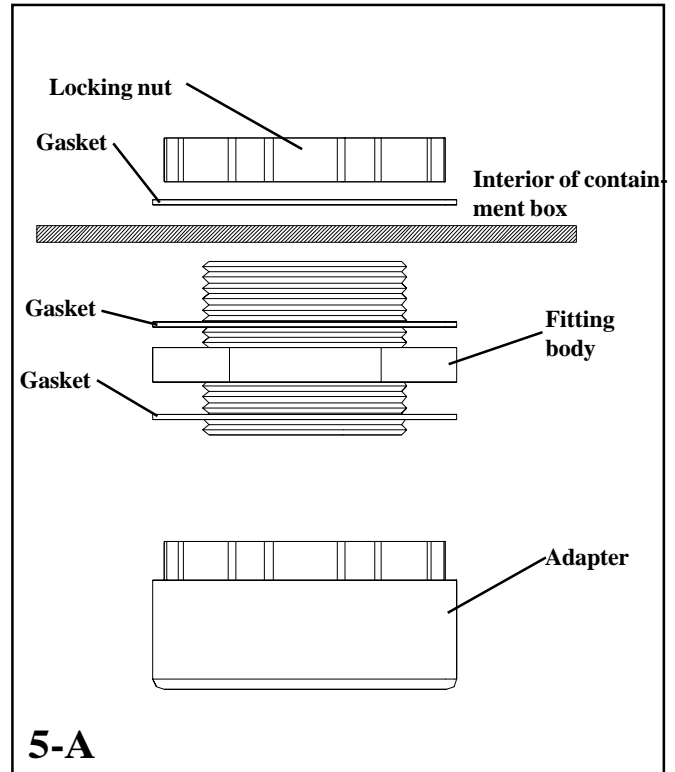

ELECTRICAL BULKHEAD SEAL (EBS-ES-1)

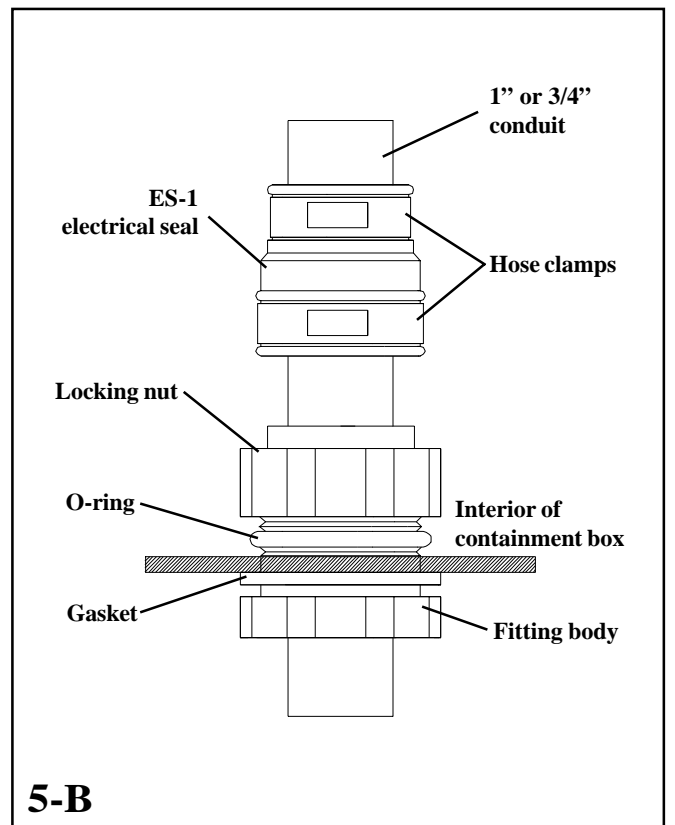

B-2000 Dispenser Containment

DISPENSER INSTALLATION

- Anchor the dispenser unto the Bravo Box using 1/2" washers and nuts on the box.

IMPORTANT: at this time follow dispenser installation instructions for proper anchoring and adjustment.

ADJUSTING THE PRODUCT SHEAR VALVE

- When the dispenser is anchored properly, the dispenser inlet or pump inlet should be plumb with the product shear valve. If the product shear valves are positioned correctly, connect them with a union. A nipple may be required to extend the dispenser riser.
- If the valve and inlet are not aligned, determine the distance necessary for the valve to be moved. To adjust the valve lengthwise and/or widthwise, loosen the 3/8" bolts on the bracket ends and on the bracket inserts (Fig. 6-A). Align valve to dispenser inlet and retighten bolts.
- To adjust the height of the valve, loosen the B-18-3 compression nut with a chain wrench, rotating it counter-clockwise. NOTE: it is not necessary to completely unthread the compression nut.

Loosen the two nuts on a U-bolt, or three bolts on a boss mounted system. Then adjust the height of the valve. NOTE: it may be necessary to loosen the compression gasket before adjusting the valve. To loosen the gasket, raise the product shear valve.

IMPORTANT: if you have inadvertently rotated the bottom nut or applied torque to the bulkhead product fitting, call the Bravo Factory at 800-282-7286. Outside U.S.A. call (323) 888-4133

- Connect dispenser riser pipe to the product shear valve. A

nipple may be required to extend the dispenser riser. *IMPORTANT: for rigid piping apply a UL classified pipe sealant for use and handling of gasoline and petroleum oils to externally threaded connections.*

- Retighten compression nut without over-tightening. Then retighten the bolts on the boss-mount bracket or the nuts on U-bolt mounting bracket. NOTE: use provided washers.
- Connect electrical and vapor lines to the dispenser as required by local code regulations. Always follow electrical and vapor component manufacturers' installation instructions.
- Seal all electrical penetrations. The factory-installed conduit penetrations should be sealed in the annular space between the conduit and the metal tube. Two methods are recommended: Bravo electrical seal-off ES-1 or UL-approved seal off compound for "cementing" the FEF (Factory Electrical Fitting). The method used should comply with local code requirements.
- Clear all debris (pea gravel, dirt, etc) from the inside of the containment box and float reservoir(s). Remove float foam cover. Check if the float chain tension is properly adjusted and connected to the shear valve and float arm. The amount of fluid or float travel to trigger shut off mechanism is dependent upon the chain tension. *IMPORTANT: Test the float system with the valve in the open position by gently raising the float tubing up approximately 1/4" to 1/2". This should shut the shear valve. See Adjusting the Float Mechanism (page 7).*
- Water leak test ONLY FIELD-INSTALLED penetration fittings. To leak-test field penetrations, fill the box with water two inches above penetrations. After a few minutes, make a visual inspection from underneath the box. If there are no leaks, remove the water with a Bravo siphon pump.
- Reset the shear valve trip mechanism to the open position.

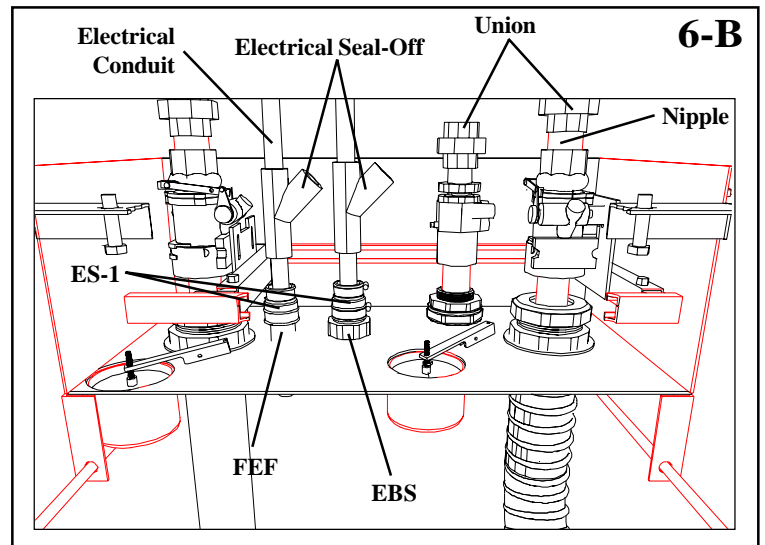
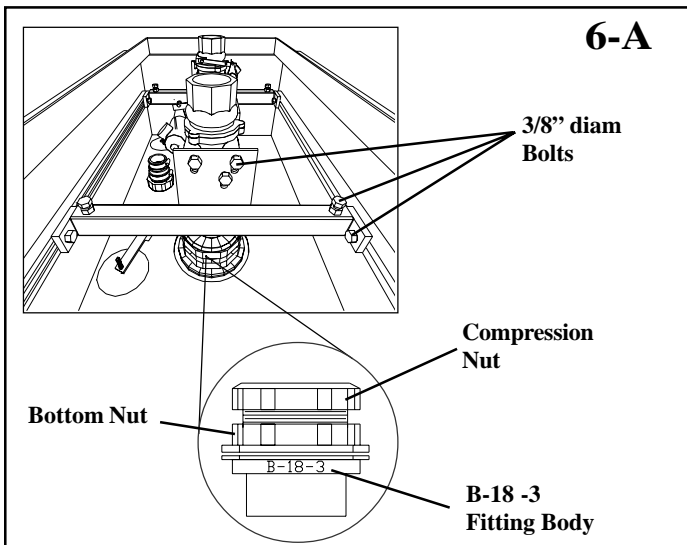

MAINTENANCE INSTRUCTIONS

CAUTION!

- *If the containment box is not performing normally when the operating instructions are followed, contact qualified service personnel or Bravo's customer service at (800) 282-7286. Outside U.S.A., call (323) 888-4133. Do not attempt to service or repair the containment box yourself.*
- *Prior to any maintenance, verify that the containment box interior is clean and free of debris and obstructions, especially in the float reservoir(s) area.*
- *Make sure that the containment box is not submerged in fuel, water or any other fluids.*
- *Do not tamper with or modify the float device or the shut-off system. This includes the lead seals and float chain. Any tampering with these components transfers the liability for the shut-off system function to the person or persons who tamper with the above components.*
- *The interior of the containment box must not be directly exposed to rock, salt, ice or snow.*

4. While removing the filter, collect as much fuel as possible from the filter before it enters the containment box. Use the manufacturer's supplied cup/collector to minimize fuel loss.
5. Next remove all fluids from the containment box. Bravo's manual siphon pump is designed to connect to the top of the float tubing for easy fluid removal. **DO NOT leave absorbent materials in the containment box to soak up fluids.**
6. Properly dispose of removed fluids according to local, state and federal regulatory guidelines.

ROUTINE FILTER CHANGES

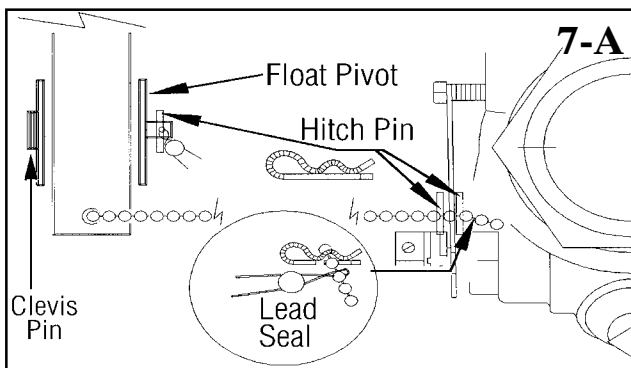

CAUTION: *prior to filter changes, follow dispenser manufacturer's instructions.*

1. Check the float chain tension for proper adjustment. Make sure it is connected to the shear valve and the float arm.
2. Next test the float system by gently raising the float tubing approximately 1/4" to 1/2" with the valve in the open position. This action should close the shear valve. If it does not, refer to Adjusting the Float Mechanism section.
3. Examine the lead seals on the float chain at the float arm pivot and at the product shear valve (Fig. 7-A). If the seals were not altered, continue with the next step. If the seals were altered, refer to the Adjusting the Float Mechanism section.

ADJUSTING THE FLOAT MECHANISM

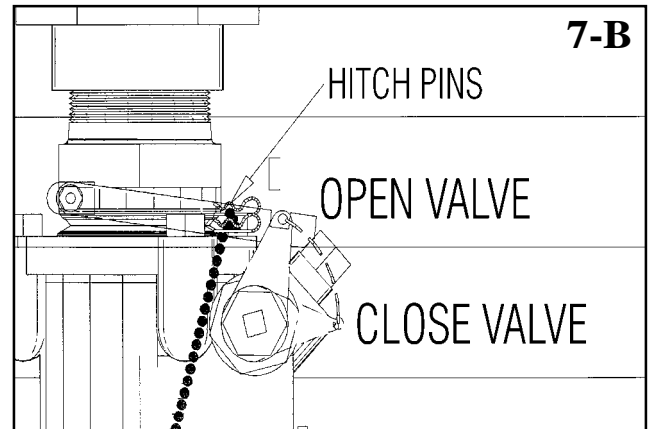

1. Remove the hitch pins from the float chain (Fig. 7-B).
2. Reset the shear valve in the open position (Fig. 7-B).
3. If a fluid test was performed, drain the float reservoir through the float tubing by using the Bravo siphon pump.
4. Properly dispose of removed fluids according to regulatory guidelines.
5. Reconnect the float chain to the valve trip mechanism (see Fig. 7-A). Put the hitch pins back in place. Retest the float-trip mechanism. Repeat until there is no slack in the chain.
6. Retest the float trip mechanism. During the retest, if the float trips the valve correctly, proceed with Step 7. **NOTE:** if the float still does not function correctly, immediately call Bravo technical assistance at (800) 282-7286. Outside USA, call (323) 888-4133.
7. Install the tamperproof lead seal on the float chain (as shown in Fig. 7-A). Twist the wire together and thread it through the lead disc. Pull the wire taut and crimp the disc. Pull the wire taut and crimp the disc.

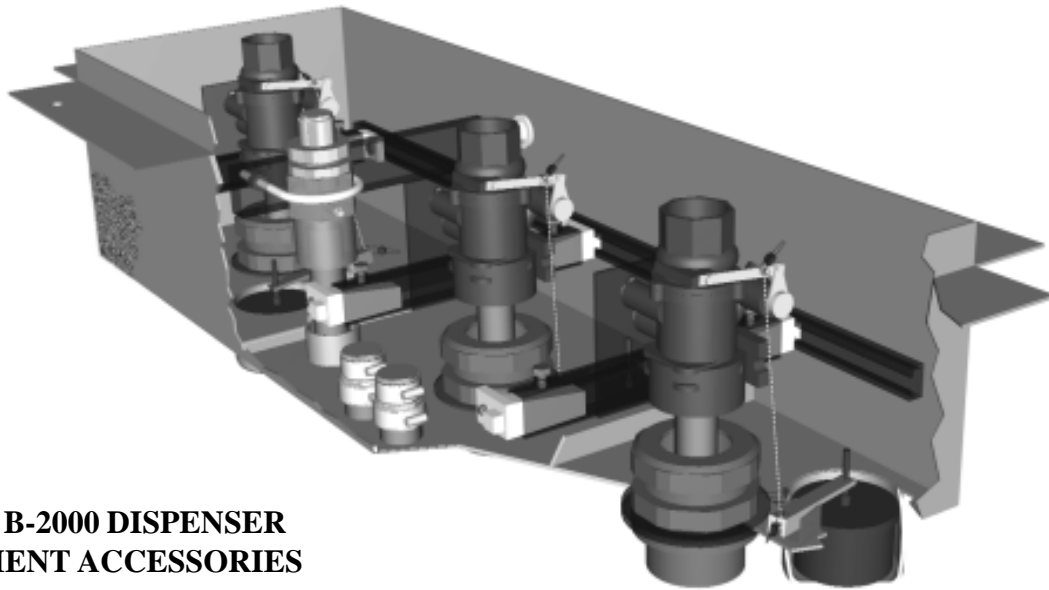

OPTIONAL B-2000 DISPENSER CONTAINMENT ACCESSORIES

PRODUCT VALVES

DPA	1-1/2" Double Poppet Valve Top Adder
DPA2	2" Double Poppet Shear Valve Adder
SPA2	2" Single Poppet Shear Valve Adder
B-18-4	Rigid 3" NPT Secondary Termination
BRKT-2	Stabilizer Bracket for 2" Shear Valve

VAPOR VALVES

B1-BASIC/TEE	Shear Fitting, Boss Mount Tee Top
B1-TOP/C	Replacement Shear Top for CARB B1
B1-T-TOP/C	Replacement Tee Shear Top for CARB B1
B1-SET/C-TEE	U-Bolt Tee Top, CARB Approved
B1-SET/CARB	U-Bolt, CARB Approved
B1-SET/UL	U-Bolt, UL Listed
B1SET-BRKT	Stabilizer Bracket for B-1 Set

VAPOR FITTINGS

FVF	Factory 1-1/2" Female NPT with 3" Secondary Adapter
FVF-NIP	Factory 1-1/2" Female NPT with 3" Secondary Adapter and 3" Nipple
FVF-NIP-1	Factory 1-1/2" Female NPT with 3" Secondary Adapter and Closed Nipple
B-27-3	B-27 Set Adapter Fitting with One Gasket for 3" Hose Termination
B-27-4	B-27 Set Adapter Fitting with One Gasket for 3" Female NPT and 4" Hose Termination
B-27-SET	Multi Purpose, 1-1/2" Female NPT
B-27SET-3	Multi Purpose, 1-1/2" for 3" Secondary Hose Termination
B-27SET-4	Multi Purpose, 1-1/2" with Female NPT 3" Secondary Rigid Termination

ELECTRICAL FITTINGS

FEF	Factory Electrical Fitting for 3/4" and 1" Conduit
FEF-ES	Factory Electrical Fitting with Reducer Seal for 3/4" and 1" Conduit
EBS	Electrical Bulkhead with Seal for 3/4" and 1" Conduit
ES-1	Electrical Reducer Seal for 3/4" and 1" Conduit (used with FEF)

MISCELLANEOUS

BFH-3-30K	3" Secondary Flex Boot 30" Length
BFH-3-40K	3" Secondary Flex Boot 40" Length
CONV-B2000	Conversion Frame (consult factory)
FA-KIT	Round Float Assembly (specify float arm length)
FC	Fiberglass Coating
MO-400	1-1/2" Offset, 1-1/2" NPT Male x Female
MO-401	1" Offset, 1-1/2" NPT Male x Female
MO-402	2" Offset, 1-1/2" NPT Male x Female
MO-403	3" Offset, 1-1/2" NPT Male x Female
SIP-PUMP	Siphon Pump (removes liquid from float)